

A10VG Series Axial piston variable pump

■ Product show and brief introduction

Colsed circuits

Series 10

Sizes 45

Nominal pressure 30MPa

Maxmum pressure 35MPa

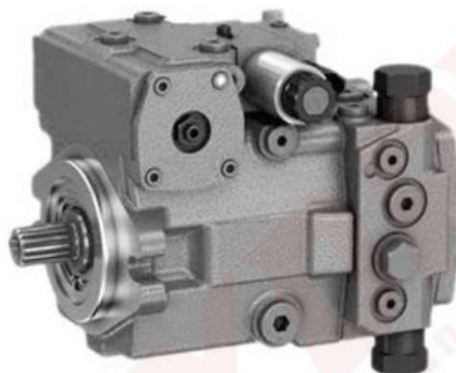

■ Features

- Integrated boost pump for bosst and pilot oil supply
- Flow direction changes when the swashplate is moved through the neutral position
- High-pressure relief valves with integrated boost function
- Boost-pressure relief valve
- Optional with pressure cut-off
- Swashplate design

Model Code

A10V	G	45	EP4	D	M.	/10	R	-N	S	C	10	F	01	3	S	P.
Axial piston unit	Operating mode	Size	Control unit	Pressure cut-off	Mechanical stroke limiter	Series	Direction of rotation	Seals	Drive shaft	Mounting flange	Working port	Boost pump	Through drive	High-pressure relief valve	Filtration	Connector for solenoids
A10V: swash-plate design, variable	G: pump; closed circuit	45	See below	No code: without pressure cut-off D: with pressure cut-off	No code: without mechanical stroke limiter M: mechanical stroke limiter, externally adjustable	10	(Viewed on drive shaft) R: clockwise L: counter-clockwise	NBR (nitrile rubber), shaft seal made of FKM (fluorocarbon rubber)	See below	C: SAE J744 2-hole F: SAE J744 2+4-hole (only 71)	SAE working port A and B, same side right, suction port S bottom	See below	See below	See below	See below	DEUTSCH connector molded, 2-pin

Control unit

Size		45	
Proportional control hydraulic	pilot-pressure related, with inlet filtration in P and X ₁ /X ₂	✓	HD3
	mechanical servo	✓	HW
Proportional control electric	with proportional solenoid with inlet filtration in P and X ₁ /X ₂	U=12V	✓ EP3
		U=24V	✓ EP4
Two-point control, electric	with switching solenoid	U=24V	✓ EZ1
		U=24V	✓ EZ2

Drive shafts

Size		45	
Splined shaft ANSI B92.a-1976	for single pump	✓	S
	for combination pump	✓	T

Boost pump

Size		45	
Without integrated boost pump	without through drive	✓	N
	with through drive	✓	K
Integrated boost pump	with and without through drive	✓	F

■ Through drive

Flange SAE J744	Hub for splined shaft			45	
Without through drive, only for version N and F				✓	00
82-2(A)	5/8"	9T	16/32DP	✓	01
101-2(B)	7/8"	13T	16/32DP	✓	02
	1"	15T	16/32DP	✓	04

■ High-pressure relief valve

	Setting range	45	
High-pressure relief valve direct operated, fixed setting	25...32MPa	without bypass	✓ 3
		with bypass	✓ 5
	10...25MPa	without bypass	✓ 4
		with bypass	✓ 6

■ Filtration boost circuit/external boost pressure supply

	45	
Filtration in the boost pump suction line	✓	S
Filtration in the boost pump pressure line Ports for external boost circuit filtration (Fe and G(Fa))	✓	D
External boost pressure supply (version without integrated boost pump -N00, K...)	✓	E

Technical Data

Hydraulic fluid

The A4VG variable displacement pump is suitable for use with mineral oil

Viscosity range

We recommend that a viscosity (at operating temperature) for optimum efficiency and service life purposes of

$$V_{opt} = \text{optimum viscosity } 16 \dots 36 \text{ mm}^2/\text{s}$$

Be chosen, taken the tank temperature (closed circuit) into account.

Limits of viscosity range

The following values apply in extreme cases:

$$V_{min} = 5 \text{ mm}^2/\text{s}$$

short term ($t < 3 \text{ min}$) at max. permitted temperature
 $t_{max} = 115^\circ\text{C}$

$$V_{max} = 1600 \text{ mm}^2/\text{s}$$

short term ($t < 3 \text{ min}$) with cold start ($P < 3 \text{ MPa}$,
 $n \leq 1000 \text{ rpm}$ $t_{min} = -40^\circ\text{C}$)

Note that the maximum hydraulic fluid temperature must not be exceeded locally either (e.g. bearing area). The temperature in the bearing area is depending on pressure and speed up to 12K higher than the average case drain temperature.

Selection diagram

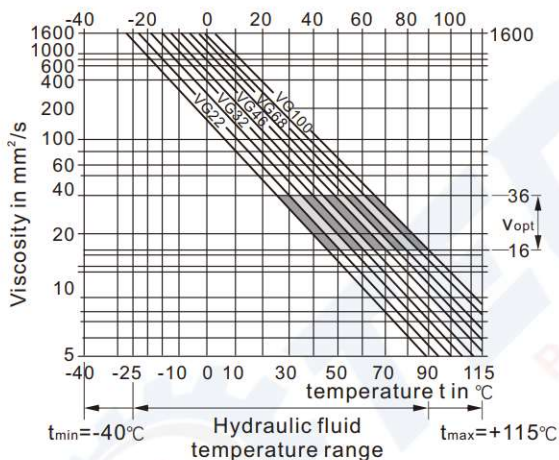

Details regarding the choice of hydraulic fluid

The correct selection of hydraulic fluid requires knowledge of the operating temperature in relation to the ambient temperature, in an open circuit the tank temperature.

The hydraulic fluid should be selected so that within the operating temperature range, the operating viscosity lies within the optimum range (V_{opt}) (see shaded section of the selection diagram). We recommend that the highest possible viscosity range should be chosen in each case.

Example: At an ambient temperature of $X^\circ\text{C}$ an operating temperature of 60°C is set in the circuit. In the optimum operating viscosity range (V_{opt} ; shaded area) this corresponds to the viscosity classes VG 46 or VG 68; to be selected: VG 68.

Please note: The leakage fluid temperature, which is affected by pressure and rotational speed, is always higher than the tank temperature. At no point in the system may the temperature be higher than 115°C .

Filtration

Finer filtration improves the cleanliness level of the hydraulic fluid, which increases the service life of the axial piston unit.

A cleanliness level of at least 20/18/15 is to be maintained according to ISO 4406.

At a hydraulic fluid viscosity of less than $10 \text{ mm}^2/\text{s}$ (e.g. due to high temperatures during short-term operation), a cleanliness level of at least 19/17/14 according to ISO 4406 is required.

Operational pressure range

Enter:

Variable pump (with external oil supply E)

With control EP, HW and HD

Charge pressure (at $n=2000 \text{ rpm}$) P_{sp} _____ = 1.8 MPa

With control DG

Charge pressure (at $n=2000 \text{ rpm}$) P_{sp} _____ = 2.5 MPa

Charge pump

Suction pressure $P_{s \text{ min}}$ ($V \leq 30 \text{ mm}^2/\text{s}$) _____ $\geq 0.08 \text{ MPa}$

Output:

Variable pump

Pressure at port A or B

Nominal pressure P_N _____ 30 MPa

Peak pressure P_{max} _____ 35 MPa

Total pressure (pressure A + pressure B) P_{max} _____ 60 MPa

Charge pump

Peak pressure $P_{sp \text{ max}}$ _____ 4 MPa

Shaft seal

Permissible pressure loading

The service life of the shaft seal is influenced by the rotational speed of the axial piston unit and the leakage pressure in the housing (case pressure). Momentary ($t < 0.1 \text{ s}$) pressure peaks of up to 1 MPa are allowed. Case pressure of a continuous 0.2 MPa maximum are permitted to be able to utilize the entire speed range. Higher case pressure are permissible at lower rotational speeds.

The service life of the shaft seal decreases with increasing frequency of pressure peaks and increasing mean differential pressure. The case pressure must be equal to or higher than the ambient pressure.

Temperature range

The FKM shaft seal ring may be used for leakage temperature from -25°C to $+115^\circ\text{C}$. For application cases below -25°C , an NBR shaft seal is required (permissible temperature range: -40°C to $+90^\circ\text{C}$).

Technical Data

Size				45
Geometric displacement, per revolution				
variable pump	$V_{g \max}$	mL/r		46
boost pump (at P=2MPa)	$V_{g \text{ sp}}$	mL/r		13,8
Rotational speed				
maximum at $V_{g \max}$	$n_{\max \text{ continuous}}$	rpm		3300
limited maximum ¹⁾	$n_{\max \text{ limited}}$	rpm		3550
intermittent maximum ²⁾	$n_{\max \text{ interm}}$	rpm		3800
minimum	n_{\min}	rpm		500
Flow				
at n_{nom} and $V_{g \max}$	$q_{v \max}$	L/min		152
Power ³⁾				
at n_{nom} and $V_{g \max}$	$\Delta P=30\text{MPa}$	P_{\max}	kW	75.9
Torque ³⁾				
with at $V_{g \max}$	$\Delta P=30\text{MPa}$	T_{\max}	Nm	220
	$\Delta P=10\text{MPa}$	T	Nm	73.2
Moment of inertia of the rotary group	J	kgm		0.0033
Maximum angular acceleration ⁴⁾		rad/s ²		4000
Maximum speed change ⁴⁾		rpm		14
Case volume	V	L		0.75
Weight(without through drive) approx.	M	kg		27

1) Valid at half corner power(e.g.at $V_{g \max}$ and $P_n/2$)

2) Valid at $\Delta P=7\text{MPa}$ to 15 MPa or $\Delta P<30\text{MPa}$ and $t<0.1\text{s}$

3) without boost pump

4) the limit value is only valid for a single pump.

Determining the nominal value

$$\text{Flow} \quad q_v = \frac{V_g \times n \times \eta_v}{1000} \quad (\text{L/min})$$

$$\text{Torque} \quad T = \frac{V_g \times \Delta P}{20 \times \pi \times \eta_{mh}} \quad (\text{Nm})$$

$$\text{Power} \quad P = \frac{2\pi \times T \times n}{60000} = \frac{q_v \times \Delta P}{600 \times \eta_t} \quad (\text{kW})$$

V_g = Displacement per revolution in mL/r

ΔP = Differential pressure in bar

n = Speed in rpm

η_v = Volumetric efficiency

η_{mh} = Mechanical-hydraulic efficiency

η_t = Overall efficiency($\eta_t = \eta_v \cdot \eta_{mh}$)

High-pressure Relief Valves

Setting ranges

High-pressure relief valve, direct operated	Differential pressure setting ΔP_{HD}
Setting range valve 3 $\Delta P_{HD} = 25-32\text{MPa}$	32 MPa
	30 MPa
	27 MPa
Setting range valve 4 $\Delta P_{HD} = 10-25\text{MPa}$	25 MPa
	23 MPa
	20 MPa
	15 MPa
	10 MPa

Setting diagram

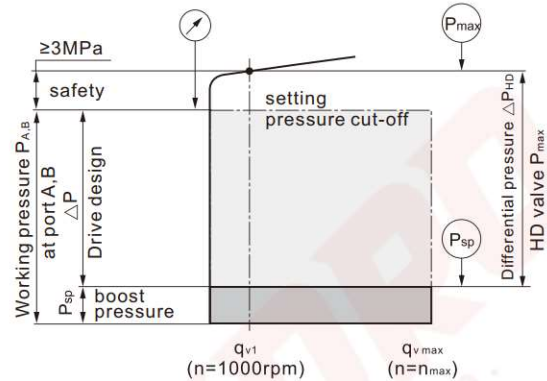

Note: the valve settings are made at $n=1000\text{rpm}$ and at $V_{gmax}(q_{v1})$,

Example: charge pressure 2 MPa, working pressure 29 MPa
 working pressure $P_{A,B}$ - Boost pressure P_{SP} = Differential pressure ΔP_{HD}
 29 MPa - 2 MPa = 27 MPa

Bypass function

A connection between the two high-pressure passages A and B can be established using the bypass function (e.g. for machine towing).

Pressure cut-off, D

The pressure cut-off is a pressure control which, after reaching the set pressure, adjusts the displacement of the pump back to V_{gmin} .

This valve prevents the operation of the high-pressure relief valves when accelerating or decelerating.

The high-pressure relief valves protect against the pressure peaks which occur during fast swiveling of the swashplate and limit the maximum pressure in the system.

The setting range of the pressure cut-off may be anywhere within the entire working pressure range. However, it must at least be set 3 MPa lower than the setting value of the high-pressure relief valves.

Please state the setting value of the pressure cut-off in plain text when ordering.

Circuit diagram with pressure cut-off

Example: Proportional control, hydraulic HW

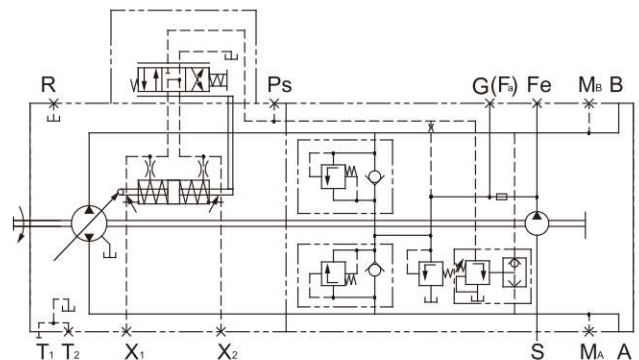

DG - Hydraulic control, direct operated

With the direct operated hydraulic control (DG), the output flow of the pump is controlled by a hydraulic control pressure, applied directly to the stroking piston through either port X1 and X2.

Flow direction is determined by which control pressure port is pressurized.

Pump displacement is infinitely variable and proportional to the applied control pressure, but is also influenced by system pressure, but is also influenced by system pressure and pump drive speed.

In order to use the optional built-in pressure cut-off, port PS must be used as source of the control pressure X1, X2.

Rotation direction-control-flow direction relationship see HD control on page 7 (control pressure X1, X2).

Circuit diagram

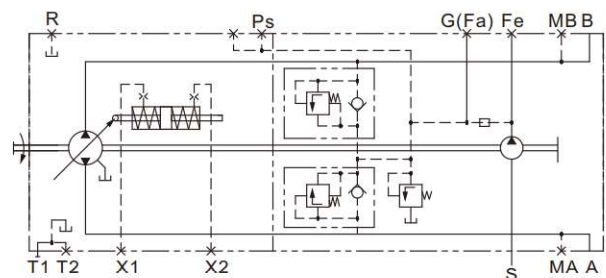

HD-Proportional control,hydraulic,pilot-pressure related

The output flow of the pump is infinitely variable between 0 and 100%,proportional to the difference in pilot pressure applied to the two pilot signal ports (Y1 and Y2).

The pilot signal,coming from an external source, is a pressure signal.Flow is negligible,as the pilot signal acts only on the control spool of the control valve.

This control spool then directs control oil into and out of the stroking cylinder to adjust pump displacement as required. A feedback lever connected to the stroking piston maintains the pump flow for any given pilot signal within the control range.

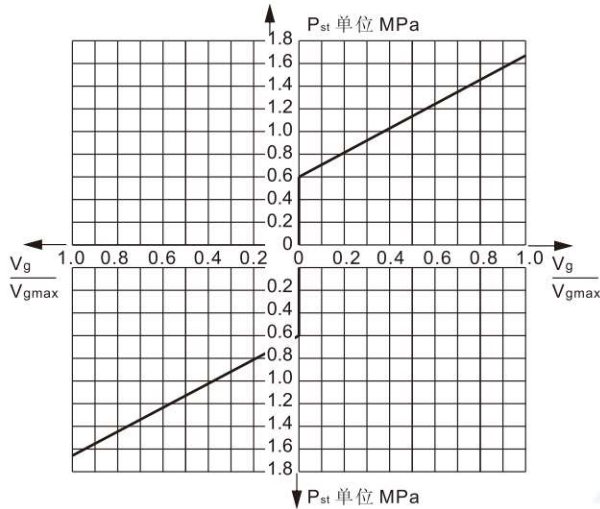

V_g Displacement
 V_{gmax} Maximum displacement

Pilot pressure $P_{st}=0.6-1.67\text{MPa}$ for Ports Y1,Y2
 Start of control 0.6MPa (at V_{g0})
 End of control 1.67MPa (at V_{gmax})

Notice:
 In the neutral position,the HD control module must be unloaded to reservoir via the external pilot control device.

Correlation of direction of rotation, control and flow direction

		Pilot signal	Control pressure	Flow direction	Working pressure
Direction of rotation	Clockwise	Y1	X1	A to B	M _B
	Counter-clockwise	Y2	X2	B to A	M _A
Direction of rotation	Counter-clockwise	Y1	X1	B to A	M _A
	Clockwise	Y2	X2	A to B	M _B

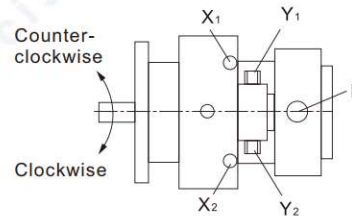
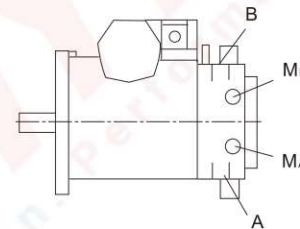

Circuit diagram HD3

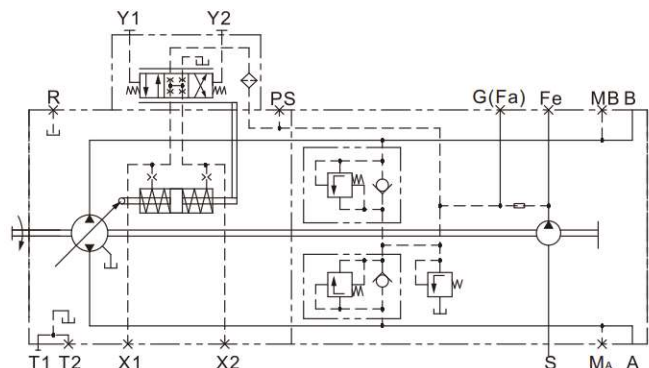

Notice

The spring in the center of the pilot control is not a safety device.

Due to contamination in the controls, such as contamination in the hydraulic oil, wear particles, and particles outside the system, the spool can become stuck in any position. In this case, the pump flow is no longer following the machine operator's command input.

-Ensures that the emergency stop function can instantly bring the motion of the driven machine to a safe level (eg stop)

-If the cleanliness level 20/18/15 (<90°C) or 19/17/14 (>90°C) specified by ISO4406 is followed

HW-Proportional control,hydraulic,mechanical servo

The output flow of the pump is infinitely variable between 0 and 100%,proportional to the swivel angle of the control lever.
A feedback lever connected to the stroking piston maintains the pump flow for any given position of the control lever.

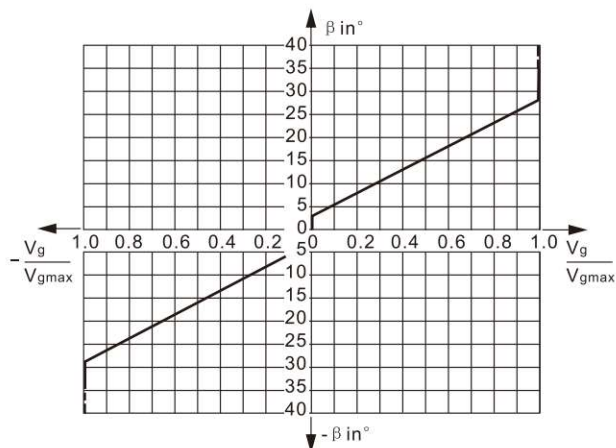

The swing angle of the lever when swinging β :
Start of control $\beta = \pm 3^\circ$ (at V_{g0})
End of control $\beta = \pm 29^\circ$ (at V_{gmax})
Rotational limiter control $\beta = \pm 40^\circ$

The maximum required torque at control lever is 170 Ncm.To prevent damage to the HW control module,a positive mechanical stop of $38^\circ \pm 1$ must be provided for the HW control lever on the customer side.

Correlation of direction of rotation, control and flow direction

Direction of rotation		Lever direction	Control pressure	Flow direction	Working pressure
Clockwise	a		X ₂	B to A	M _A
	b		X ₁	A to B	M _B
Counter-clockwise	a		X ₂	A to B	M _B
	b		X ₁	B to A	M _A

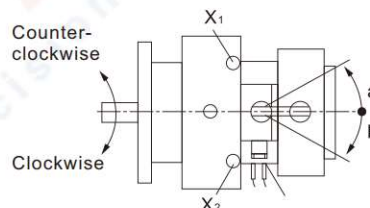
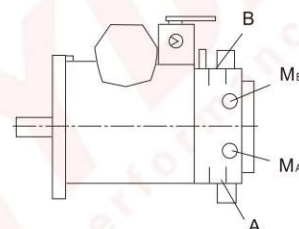

Circuit diagram HW

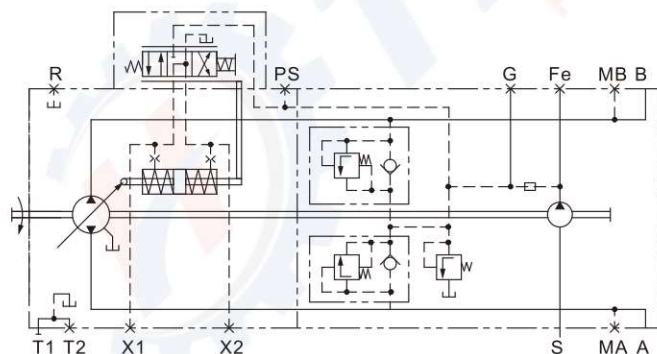

EP-Proportional control, electric

The output flow of the pump is infinitely variable between 0 and 100%, proportional to the electric current supplied to solenoid a or b.

The electrical energy is converted into a force acting on the control spool. This control spool then directs control oil into and out of the stroking cylinder to adjust pump displacement as required. A feedback lever connected to the stroking piston maintains the pump flow for any given current within the control range.

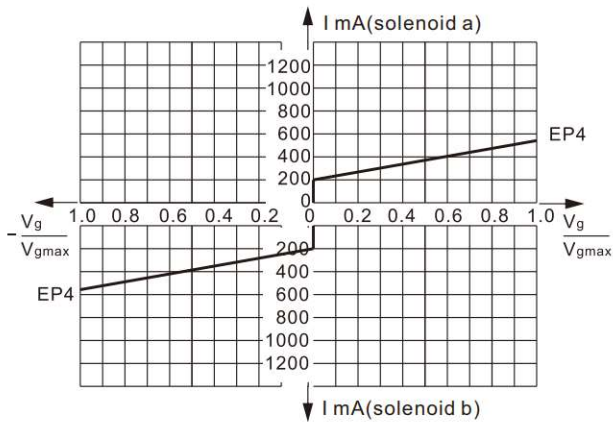

Notice:

The proportional solenoid do not have manual override. Proportional solenoid with manual override and spring return are available on request.

Technical data, proportional solenoid	EP3	EP4
Voltage	12V DC(±20%)	24V DC(±20%)
Control current		
Start of control at V_{g0}	400mA	200mA
End of control at V_{gmax}	1200mA	600mA
Current limit	1.54A	0.77A
Nominal resistance(at 20°C)	5.5Ω	22.7Ω
Frequency	100Hz	100Hz
Duty cycle	100%	100%
Type of protection	Ip65	

Notice

The spring in the center of the pilot control is not a safety device.

Due to contamination in the controls, such as contamination in the hydraulic oil, wear particles, and particles outside the system, the spool can become stuck in any position. In this case, the pump flow is no longer following the machine operator's command input.

– Ensures that the emergency stop function can instantly bring the motion of the driven machine to a safe level (eg stop)

-If the cleanliness level 20/18/15 (<90°C) or 19/17/14 (>90°C) specified by ISO4406 is followed

Correlation of direction of rotation, control and flow direction

Direction of rotation		Actuation of proportional solenoid	Control pressure	Flow direction	Working pressure
Clockwise	a	X ₁	A to B	M _B	
	b	X ₂	B to A	M _A	
Counter-clockwise	a	X ₁	B to A	M _A	
	b	X ₂	A to B	M _B	

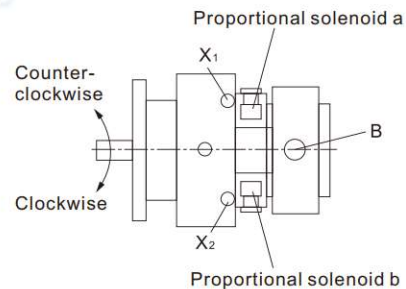
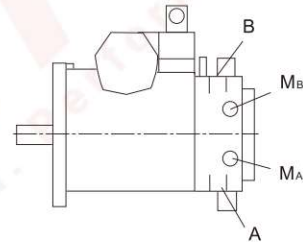

EZ-Two-point control, electric

By actuating either switching solenoid a or b, internal control pressure is applied directly to the stroking piston and the pump swivels to maximum displacement.

The EZ control enables pump flow to be switched between $V_g=0$ and $V_g \text{ max}$.

Flow direction is determined by which solenoid is energized.

Technical data, switching solenoid	EZ1	EZ2
Voltage	12V DC($\pm 20\%$)	24V DC($\pm 20\%$)
Neutral position $V_g=0$	de-energized	de-energized
Position $V_g \text{ max}$	current switched on	current switched on
Nominal resistance(at 20°C)	5.5Ω	22.7Ω
Nominal power	26.2W	26.5W
Minimum required active current	1.32A	0.67A
Duty cycle	100%	100%
Type of protection	IP65	

Standard : switch electromagnet without manual emergency operation function. Manual emergency operation via spring return is available on request.

Correlation of direction of rotation, control and flow direction

		Actuation of proportional solenoid	Control pressure	Flow direction	Working pressure
Direction of rotation	Clockwise	a	X ₂	B to A	M _A
		b	X ₁	A to B	M _B
	Counter-clockwise	a	X ₂	A to B	M _B
		b	X ₁	B to A	M _A

Circuit diagram EZ

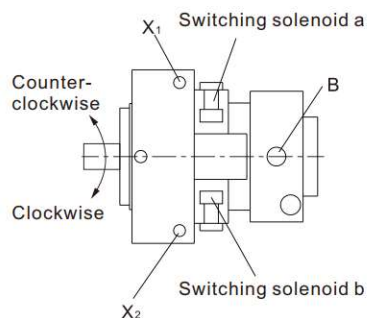
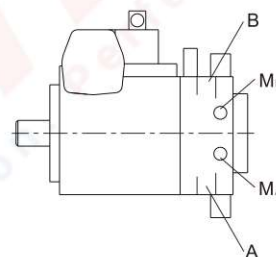
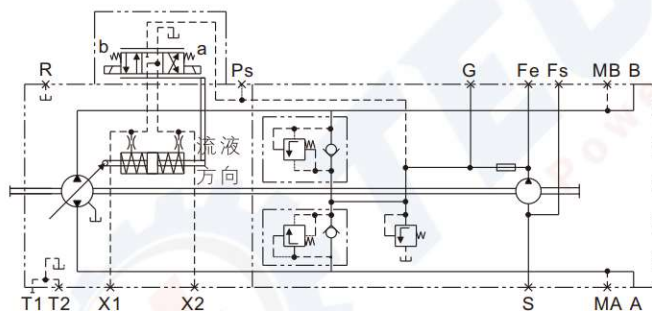

Installation dimensions

Without control valve

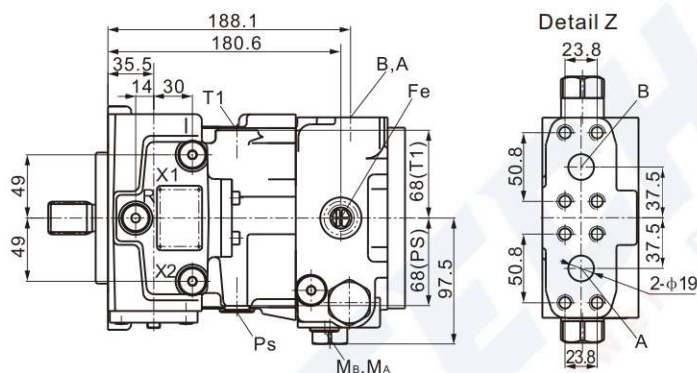
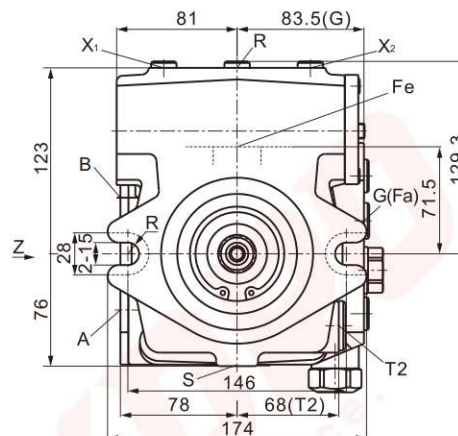
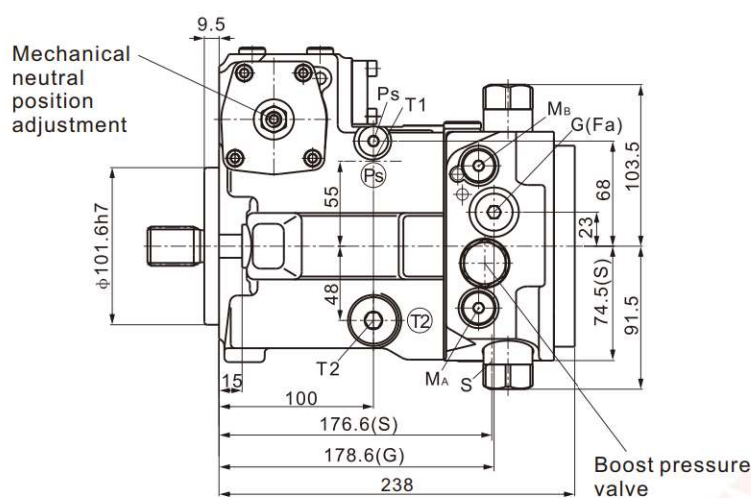

Ports

A, B	Working port	3/4 in
	Fastening thread	M10; 17 deep
S	Suction port	M33×2; 15 deep
T ₁	Drain port	M22×1.5; 15 deep
T ₂	Drain port	M22×1.5; 15 deep
M _A , M _B	Measuring port pressure A, B	M12×1.5; 12 deep
R	Air bleed port	M12×1.5; 15 deep
X ₁ , X ₂	Control pressure port (upstream of orifice)	M12×1.5; 12 deep
G(F _a)	Boost pressure port inlet	M18×1.5; 12 deep
P _s	Pilot pressure port	M14×1.5; 12 deep
F _e	Boost pressure port outlet	M18×1.5; 12 deep

Shafts

S spline shaft SAE J744
1 in 15T 16/32DP

T spline shaft SAE J744
1 1/4 in 14T 12/24DP

L spline shaft SAE J744
with connecting flange

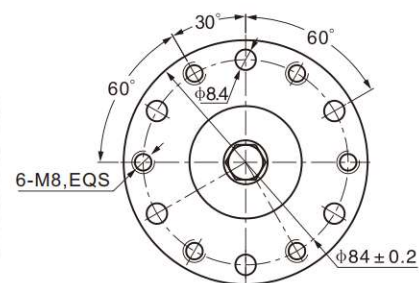
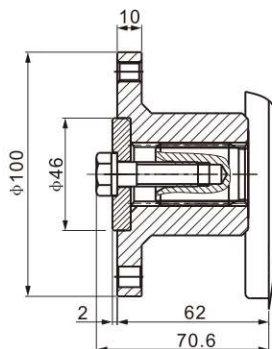
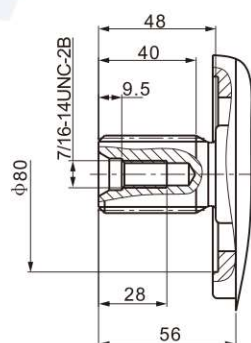
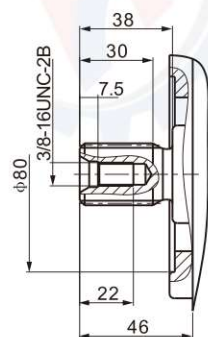

■ Installation dimensions

HD-Proportional control,hydraulic,
pilot-pressure related

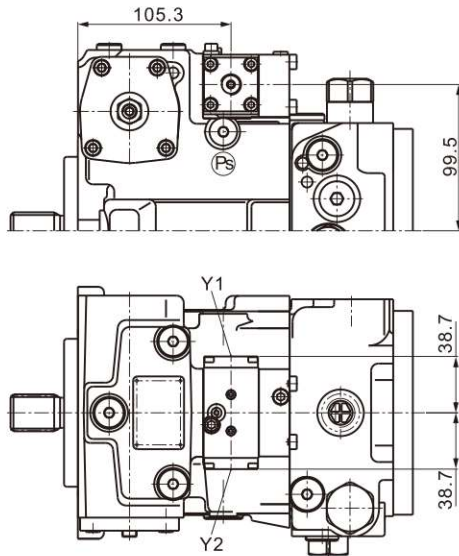

Y1,Y2 Pilot pressure port outlet M14×1.5;12 deep

HW-Proportional control,hydraulic,
mechanical servo

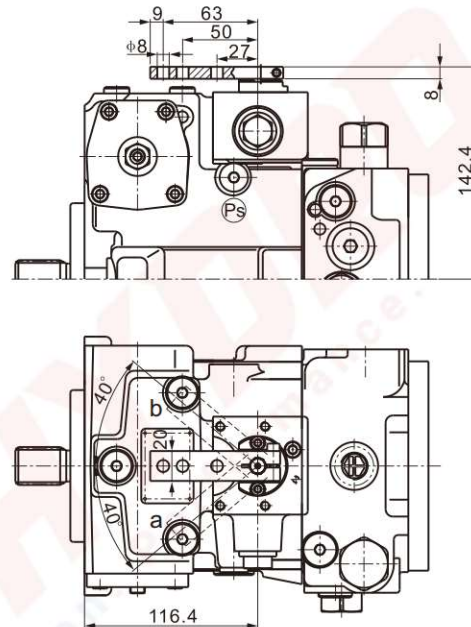

EP-Proportional control,electric

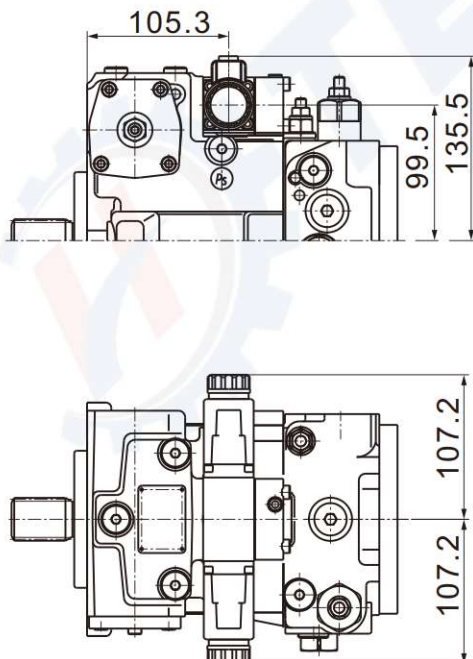

EZ-Two point control,electric

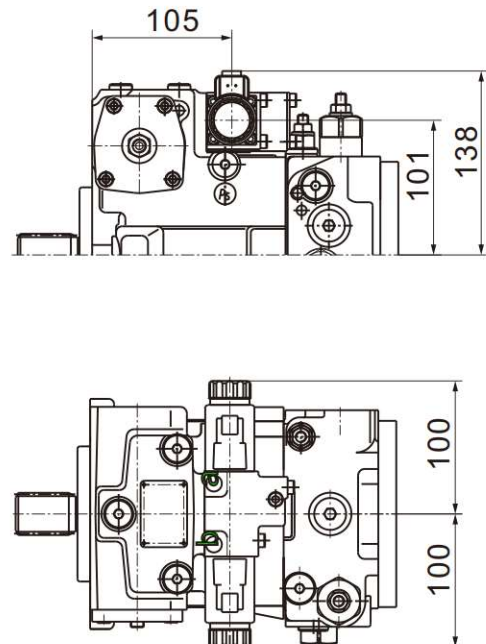

■ Installation dimensions, through drive

N00-without boost pump
F00-with boost pump

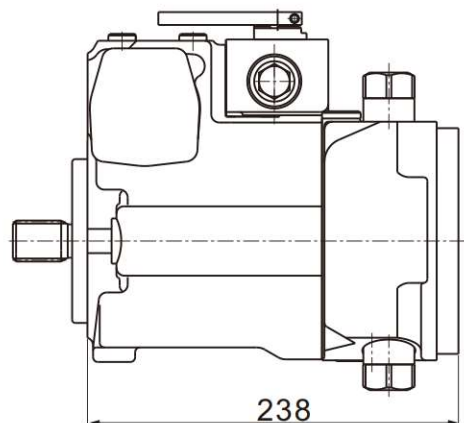

Flange SAE J744-82-2(A)
Coupler for splined shaft acc.to ANSI B92, 1a-1976

F02/K02
Flange SAE J744
Spline shaft sleeve to ANSI B92.1
7/8in 13T 16/32DP¹⁾

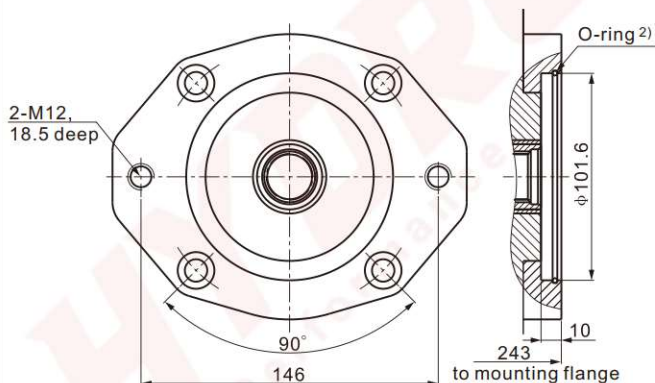

F01/K01
Flange SAE J744
Spline shaft sleeve to ANSI B92.1
5/8in 9T 16/32DP¹⁾

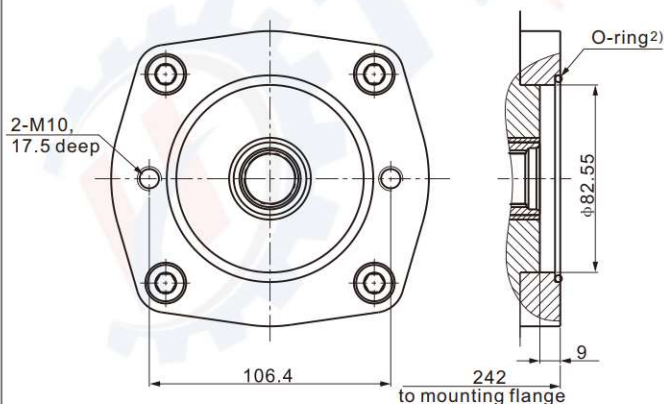

F04/K04
Flange SAE J744
Spline shaft sleeve to ANSI B92.1
1in 15T 16/32DP¹⁾

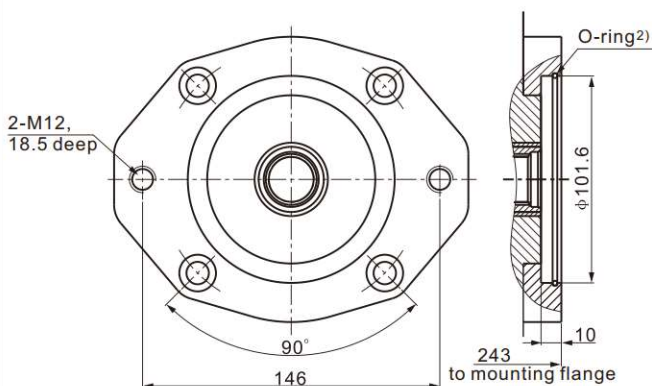

1) Involute spline according to ANSI B92.1a, 30° pressure angle, flat root, side fit, tolerance class 5

2) O-ring included in the scope of delivery

Note: please state in plain text whether the 2-hole horizontal or the 2-hole vertical version is used.

Installation instructions

General

The axial piston unit must be filled with hydraulic fluid and air bled during commissioning and operation. This must also be observed following a longer standstill as the axial piston unit may empty via the hydraulic lines.

Particularly in the installation position "drive shaft upwards", filling and air bleeding must be carried out completely as there is, for example, a danger of dry running.

The leakage in the housing area must be directed to the reservoir via the highest drain port (T1, T2).

For combination pumps, the leakage must be drained off at each single pump.

If a shared drain line is used for several units, make sure that the respective case pressure in each unit is not exceeded. The shared drain line must be dimensioned to ensure that the maximum permissible case pressure of all connected units is not exceeded in any operating condition, particularly at cold start. If this is not possible, separate drain lines must be laid, if necessary.

To achieve favorable noise values, decouple all connecting lines using elastic elements and avoid above-reservoir installation.

Under all operating conditions, the suction line and drain line must flow into the reservoir below the minimum fluid level. The permissible suction height $h_{s \max}$ results from the total pressure loss; it must not, however, be higher than $h_{s \max} = 800$ mm.

The suction pressure at port S must also not fall below the minimum value of 0.8 bar absolute during operation (cold start 0.5 bar absolute).

Installation position

See the following example. Other installation positions available upon request.

Below-reservoir installation (standard)

Below-reservoir installation means that the axial piston unit is installed outside of the reservoir below the minimum fluid level.

Above-reservoir installation

Above-reservoir installation means that the axial piston unit is installed above the minimum fluid level of the reservoir. Observe the maximum permissible suction height $h_{s \max} = 800$ mm.

Recommendation for installation position 8 (drive shaft upward): A check valve in the drain line (cracking pressure 0.5 bar) can prevent the housing area from draining.

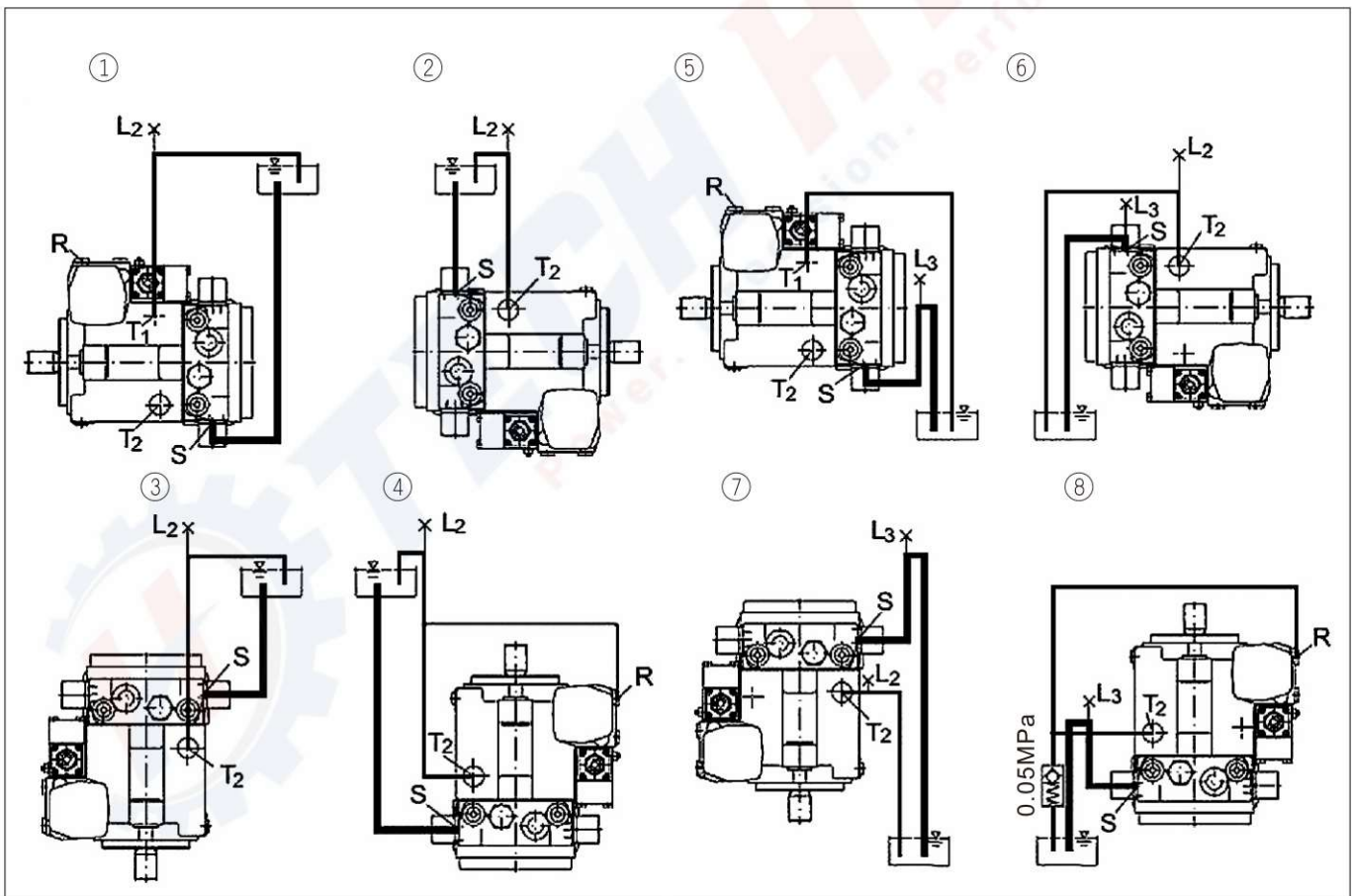

Installation position	Air bleed the housing	Filling
1	R	S+T1(L2)
2	L2	S+T2(L2)
3	L2	S+T2(L2)
4	R+L2	S+T2(L2)

Installation position	Air bleed the housing	Filling
5	R	T1+(L3)
6	L2	S(L3)+T2(L2)
7	L2+L3	S(L3)+T2(L2)
8	R+L3	S(L3)+T2

FOR MORE INFORMATION PLEASE CONTACT US

SALES@TECHYDRO.COM.CN



TECHYDRO

- +86-15869517019
- SALES@techhydro.com.cn
- WWW.TECHYDRO.COM.CN
- whatsapp/Wechat: +86-15869517019
- TEL: +86(0574) -87021030