

A11V(L) O Series Axial piston variable pump

■ Product show and brief introduction

open circuits

Series 1
Sizes 40 to 260
Nominal pressure 35MPa
Maximum pressure 40MPa

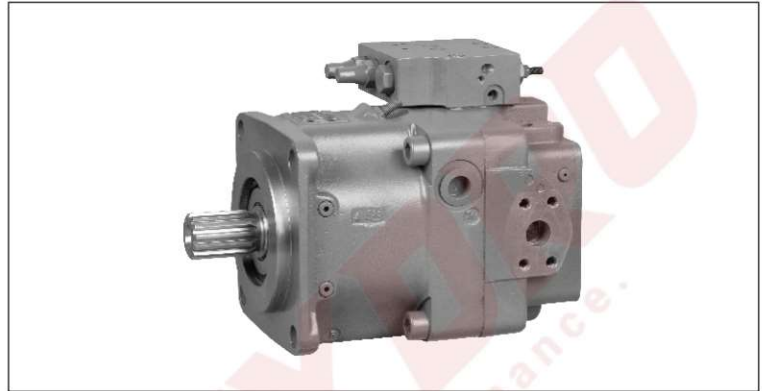

■ Features

- Variable axial piston pump of swashplate design for hydrostatic drives in open circuit hydraulic system.
- Designed primarily for use in mobile applications.
- The pump operates under self-priming conditions, with tank pressurization, or with an optional built-in charge pump (impeller).
- A comprehensive range of control options is available matching any application requirement.
- Power control option is externally adjustable, even when the pump is running.
- The through drive is suitable for adding gear pumps and axial piston pumps up to the same, i.e. 100% through drive.
- The output flow is proportional to the drive speed and infinitely variable between q_{vmax} and $q_{vmin}=0$

Model Code

A11V	L	O	145	LRDS	/10	R	-N	Z	D	12	N00
Axial piston unit	Charge pump	Operation	Size	Control unit	series	Direction of rotation	Seals	Drive shaft	Mounting flange	Service line ports	Through drive
A11V: swashplate design, variable	No code: without charge pump L: with charge pump (only 130, 145, 190)	O: pump, open circuit	40 60 75 95 115 130 145 190 260	See below	10: size 40 to 115 11: size 130 to 190	(Viewed from shaft end) R: clockwise L: counter-clockwise	NBR(nitrile-caoutchouc), shaft seal ring in FKM (fluor-caoutchouc)	See below	C: SAE J744 -2 hole (only Ng60) D: SAE J744 -4 hole	Pressure and suction port SAE, at side, opposite side (with metric fastening threads)	See below

Control unit

Size		40	60	75	95	115	130	145	190	260	
Power control/pressure cut-off/ stroke limiter	U=12V	✓	✓	✓	✓	✓	✓	✓	✓	✓	LRDU1
	U=24V	✓	✓	✓	✓	✓	✓	✓	✓	✓	LRDU2
Positive characteristic	U=12V	✓	✓	✓	✓	✓	✓	✓	✓	✓	LRDU2
	U=24V	✓	✓	✓	✓	✓	✓	✓	✓	✓	LRDU2
Power control/pressure cut-off/ stroke limiter	Δp=25bar	/	/	0	0	0	0	0	✓	✓	LRDH2
	Δp=10bar	/	/	✓	/	✓	/	✓	/	/	LRDH6
Power control/pressure cut-off/load sensing		✓	✓	✓	✓	✓	✓	✓	✓	✓	LRDS
power control, with electronic unauthorized /load sensing	Negative U=12V	/	/	/	✓	✓	✓	✓	✓	✓	LE1S
	U=24V	/	/	/	✓	✓	✓	✓	✓	✓	LE2S
	Electric, prop.override U=24V	/	/	/	✓	✓	✓	✓	✓	✓	LE2S2
Pressure control with load sensing		/	/	✓	✓	✓	✓	✓	✓	✓	DRS
Electric control with proportional solenoid	Positive characteristic U=12V	/	/	0	✓	✓	✓	✓	✓	✓	EP1
		U=24V	/	/	0	✓	✓	✓	✓	✓	EP2
	With pressure cut-off positive characteristic U=12V	✓	✓	0	✓	✓	✓	✓	✓	✓	EP1D
		U=24V	✓	✓	0	✓	✓	✓	✓	✓	EP2D

Drive shafts

Size		40	60	75	95	115	130	145	190	260	
Splined shaft DIN5480 for single and combination pump		✓	✓	✓	✓	✓	✓	✓	✓	✓	Z
Parallel keyed shaft DIN6885		✓	✓	✓	✓	✓	✓	✓	✓	✓	P
Splined shaft ANSI B92.1a-1976	for single pump	✓	✓	✓	✓	✓	✓	✓	✓	✓	S
	for combination pump	✓	✓	✓	✓	✓	/ ¹⁾	/ ¹⁾	✓	✓	T

Through Drives

Flange SAE J744	Coupler for splined shaft		40	60	75	95	115	130	145	190	260	
Without through drive			✓	✓	✓	✓	✓	✓	✓	✓	✓	N00
82-2(A)	5/8"	9T 16/32DP (A)	✓	✓	✓	✓	✓	✓	✓	✓	✓	K01
	3/4"	11T 16/32DP (A-B)	✓	✓	✓	✓	✓	✓	✓	✓	✓	K52
101-2(B)	7/8"	13T 16/32DP (B)	✓	✓	✓	✓	✓	✓	✓	✓	✓	K02
	1"	15T 16/32DP (B-B)	✓	✓	✓	✓	✓	✓	✓	✓	✓	K04
	W35	2x30x16-9g	✓	✓	✓	✓	✓	✓	✓	✓	✓	K79
127-2(C)	1 1/4"	14T 12/24DP (C)	/	✓	✓	✓	✓	✓	✓	✓	✓	K07
	1 1/2"	17T 12/24DP (C-C)	/	/	/	✓	✓	✓	✓	✓	✓	K24
	W30	2x30x14-9g	/	✓	✓	✓	✓	✓	✓	✓	✓	K80
	W35	2x30x16-9g	/	✓	✓	✓	✓	✓	✓	✓	✓	K61
152-4(D)	1 1/4"	14T 12/24DP (C)	/	/	✓	✓	✓	✓	✓	✓	✓	K86
	1 3/4"	13T 8/16DP (D)	/	/	/	/	/	✓	✓	✓	✓	K17
	W40	2x30x18-9g	/	/	✓	✓	✓	✓	✓	✓	✓	K81
	W45	2x30x21-9g	/	/	/	✓	✓	✓	✓	✓	✓	K82
	W50	2x30x24-9g	/	/	/	/	/	✓	✓	✓	✓	K83
165-4(E)	1 3/4"	13T 8/16DP (D)	/	/	/	/	/	/	/	✓	✓	K72
	W50	2x30x24-9g	/	/	/	/	/	/	/	✓	✓	K84

✓ = available / = not available

1) S-shaft suitable combination pump.

Technical Data

Hydraulic fluid

The A11V(L)O variable displacement pump is suitable for use with mineral oil

Viscosity range

For optimum efficiency and service life, select an operating viscosity (at operating temperature) within the optimum range of

$$V_{opt} = \text{optimum viscosity } 16 \dots 36 \text{ mm}^2/\text{s}$$

depending on the tank temperature (open circuit).

Limits of viscosity range

The limiting values for viscosity are as follows:

$V_{min} = 5 \text{ mm}^2/\text{s}$
 short-term ($t < 3 \text{ min}$)
 At max. perm. temperature of $t_{max} = +115^\circ\text{C}$

$V_{max} = 1600 \text{ mm}^2/\text{s}$
 short-term ($t < 3 \text{ min}$)
 At cold start ($P < 3 \text{ MPa}$, $n \leq 1000 \text{ rpm}$, $t_{min} = -40^\circ\text{C}$).
 Only for starting up without load. Optimum operating viscosity must be reached within approx. 15 minutes.

Note that the maximum hydraulic fluid temperature of 115°C must not be exceeded locally either (e.g. bearing area). The temperature in the bearing area is depending on pressure and speed up to 5 K higher than the average case drain temperature.

Special measures are necessary in the temperature range from -40°C and -25°C (cold start phase), please contact us.

Selection diagram

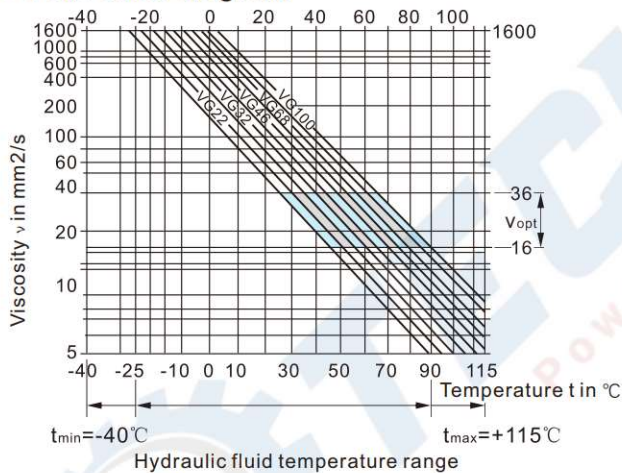

Details regarding the choice of hydraulic fluid

The correct selection of hydraulic fluid requires knowledge of the operating temperature in relation to the ambient temperature, in an open circuit the tank temperature.

The hydraulic fluid should be selected so that within the operating temperature range, the operating viscosity lies within the optimum range (V_{opt}) (see shaded section of the selection diagram). We recommend that the highest possible viscosity range should be chosen in each case.

Example: At an ambient temperature of $X^\circ\text{C}$ an operating temperature of 60°C is set in the circuit. In the optimum operating viscosity range (V_{opt} ; shaded area) this corresponds to the viscosity classes VG 46 or VG 68; to be selected: VG 68.

Please note: The leakage fluid temperature, which is affected by pressure and rotational speed, is always higher than the tank temperature. At no point in the system may the temperature be higher than 115°C .

If the above conditions cannot be maintained due to extreme operating parameters, please contact us.

Filtration

The finer the filtration, the higher the cleanliness level of the hydraulic fluid and the longer the service life of the axial piston unit.

To ensure functional reliability of the axial piston unit, the hydraulic fluid must have a cleanliness level of at least

20/18/15 according to ISO 4406.

At very high hydraulic fluid temperatures (90°C to max. 115°C), at least cleanliness level

19/17/14 according to ISO 4406 is required.

If the above classes cannot be observed, please contact us.

Maximum permissible speed (speed limit)

Permissible speed by increasing the inlet pressure p_{abs} at the suction port S or at $V_g \leq V_{gmax}$

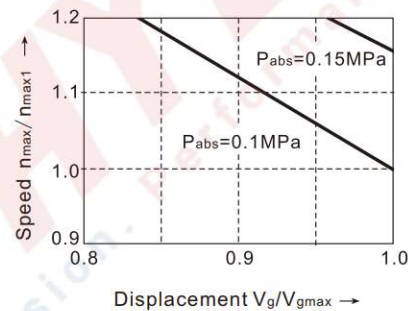

Operating pressure range - Inlet

Absolute pressure at port S (suction port)
 Version without charge pump

$P_{abs \text{ min}}$ _____ 0.08 MPa
 $P_{abs \text{ max}}$ _____ 0.3 MPa

If the pressure is $> 0.5 \text{ MPa}$, please ask.

Version with charge pump

$P_{abs \text{ min}}$ _____ 0.06 MPa
 $P_{abs \text{ max}}$ _____ 0.2 MPa

Operating pressure range - outlet

Pressure at port A or B

Nominal pressure P_N _____ 35 MPa
 Maximum pressure P_{max} _____ 40 MPa

Case drain pressure

The case drain pressure at the ports T_1 and T_2 may be a maximum of 0.12 MPa higher than the inlet pressure at the port S but not higher than

$P_{L \text{ abs. max}}$ _____ 0.2 MPa

An unrestricted, full size case drain line directly to tank is required.

■ Technical Data

● Table of values (theoretical values, without efficiency and tolerances; values rounded)

Size	A11VO	40	60	75	95	115	130	145	130	145	190	260	
	A11VLO(with charge pump)												
Displacement	$V_{g \max}$	mL/r	42	58.5	74	93.5	115	130	145	130	145	193	260
	$V_{g \min}$	mL/r	0	0	0	0	0	0	0	0	0	0	0
Speed	maximum at $V_{g \max}$ ¹⁾	n_{\max}	rpm	3000	2700	2550	2350	2350	2100	2200	2500	2500	2300
	maximum at $V_g \leq V_{g \max}$ ³⁾	$n_{\max 1}$	rpm	3500	3250	3000	2780	2780	2500	2500	2500	2500	2300
Flow at n_{\max} and $V_{g \max}$	$q_{v \max}$	L/min	126	158	189	220	270	273	319	325	363	483	598
Power at $q_{v \max}$ and $\Delta P=35\text{MPa}$	P_{\max}	kW	74	92	110	128	158	159	186	190	211	281	349
Torque at $V_{g \max}$ and $\Delta P=35\text{MPa}$	T_{\max}	Nm	234	326	412	521	641	724	808	724	808	1075	1448
Moment of inertia for rotary group	J	Kgm ²	0.0048	0.0082	0.0115	0.0173	0.0173	0.0318	0.0341	0.0337	0.036	0.0577	0.0895
Filling capacity	V	L	1.1	1.35	1.85	2.1	2.1	2.9	2.9	2.9	2.9	3.8	4,6
Weight(approx.)	V	kg	32	40	45	53	53	76	76	72	73	104	138

1) The values apply at absolute pressure (P_{abs}) 0.1MPa at the suction port S and mineral hydraulic fluid.

2) The values apply at $V_g < V_{g \max}$ or in case of an increase in the inlet pressure P_{abs} at the suction port S.

● Determining the nominal value

$$\text{Flow } q_v = \frac{V_g \times n \times \eta_v}{1000} \quad (\text{L/min})$$

$$\text{Torque } T = \frac{V_g \times \Delta P}{20 \times \pi \times \eta_{mh}} \quad (\text{Nm})$$

$$\text{Power } P = \frac{2\pi \times T \times n}{60000} = \frac{q_v \times \Delta P}{600 \times \eta_t} \quad (\text{kW})$$

V_g = Displacement per revolution in mL/r

ΔP = Differential pressure in bar

n = Speed in rpm

η_v = Volumetric efficiency

η_{mh} = Mechanical-hydraulic efficiency

η_t = Overall efficiency ($\eta_t = \eta_v \cdot \eta_{mh}$)

LR - Power Control

The power control regulates the displacement of the pump depending on the operating pressure so that a given drive power is not exceeded at constant drive speed.

$$P_B \times V_g = \text{constant}$$

P_B = operating pressure
 V_g = displacement

The precise control with a hyperbolic control characteristic provides an optimum utilization of available power.

The operating pressure acts on a rocker via a measuring piston. An externally adjustable spring force counteracts this, it determines the power setting.

If the operating pressure exceeds the set spring force, the control valve is actuated by the rocker, the pump swivels back (direction $V_{g \min}$). The lever length at the rocker is shortened and the operating pressure can increase at the same rate as the displacement decreases without the drive powers being exceeded ($P_B \times V_g = \text{constant}$).

The hydraulic output power (characteristic LR) is influenced by the efficiency of the pump.

State in clear text in the order:

- drive power P in kW
- drive speed n in prm
- max. flow $q_{v \max}$ in L/min

After clarifying the details a power diagram can be created by our computer.

Characteristic LR

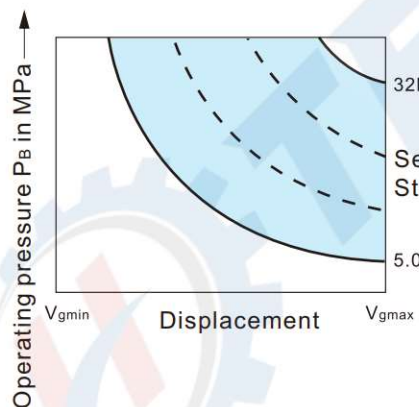

Circuit diagram LR

Size: 40...145

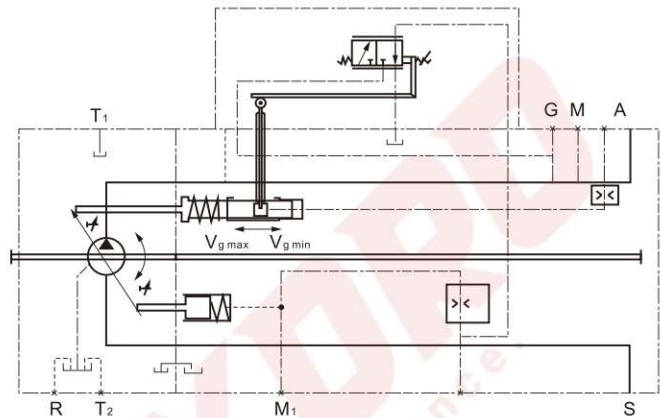

Size: 190...260

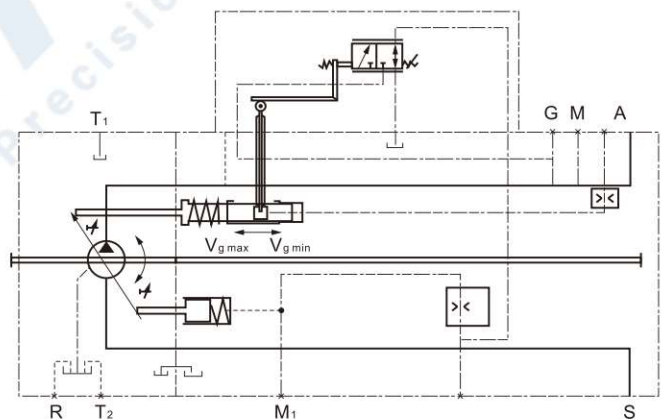

■ LR - Power Control

● LE1/2 Electric override (negative)

Contrary to hydraulic power control override, the basic power setting is reduced by an electric pilot current applied to a proportional solenoid. The resulting force is acting against the mechanical power control adjustment spring.

The mechanically adjusted basic power setting can be varied by means of different control current settings.

Increase in current = decrease in power

If the pilot current signal is adjusted by a load limiting control the power consumption of all actuators will be reduced to match the available power from the diesel engine.

A 12V(LE1) or 24V(LE2) supply is required for the control of the proportion solenoid.

Technical data - solenoids

	LE1	LE2
Voltage	12V DC (±20%)	24V DC (±20%)
Control current		
Start of control	400mA	200mA
End of control	1200mA	600mA
Limiting current	1.54A	0.77A
Nominal resistance(at 20°C)	5.5Ω	22.7Ω
Dither frequency	100Hz	100Hz
Actuated time	100%	100%
Type of protection	IP65	

Circuit diagram LE1/2

Size:40...145

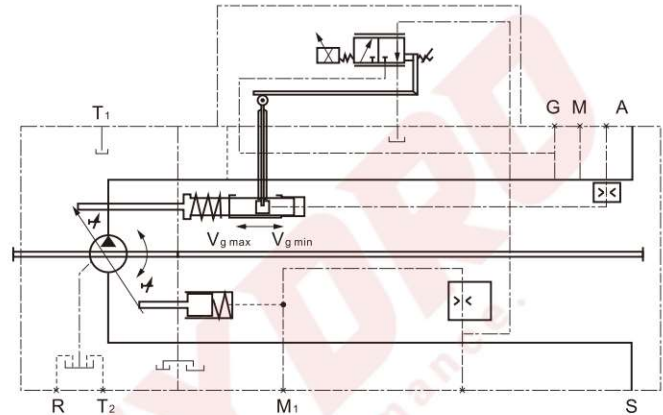

Size:190...260

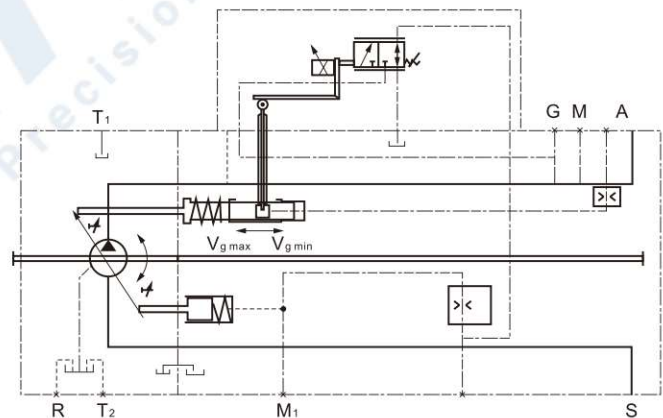

■ LR - Power Control

● LRD Power control with pressure cut-off

The pressure cut-off corresponds to a pressure control which adjusts the pump displacement back to $V_{g\min}$, when the pressure setting is reached.

This function overrides the power control, i.e. below the preset pressure value, the power function is effective.

The pressure cut-off function is integrated into the pump control module and is preset to a specified value at the factory.

Setting range from 5 to 35 Mpa.

Characteristic LRD

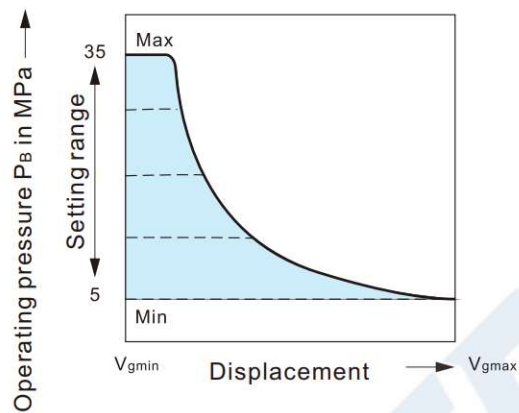

Circuit diagram LRD

Size:40...145

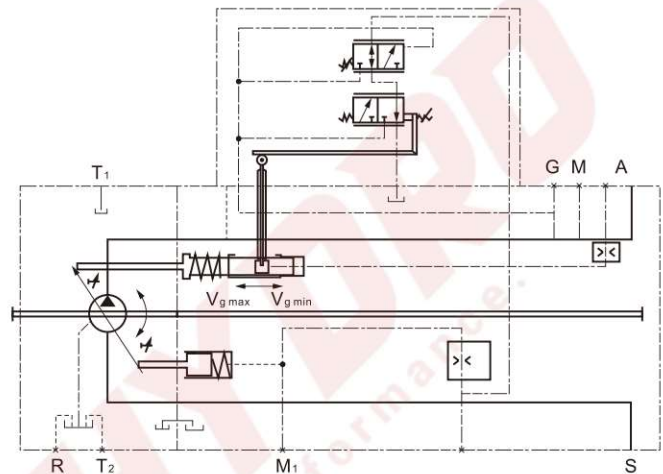

LR - Power Control

LRDS Power control with pressure cut-off and load sensing

The load sensing control is a flow control option that operates as a function of the load pressure to regulate the pump displacement to match the actuator flow requirement.

The flow depends here on the cross section of the external sensing orifice (1) fitted between the pump outlet and the actuator. The flow is independent of the load pressure below the power curve and the pressure cut-off setting and within the control range of the pump.

The sensing orifice is usually a separately arranged load sensing directional valve (control block). The position of the directional valve piston determines the opening cross section of the sensing orifice and thus the flow of the pump.

The load sensing control compares pressure before and after the sensing orifice and maintains the pressure drop across the orifice (differential pressure ΔP) and with it the pump flow constant.

If the differential pressure ΔP increases at the sensing orifice, the pump is swivelled back (towards $V_{g \min}$), and, if the differential pressure ΔP decreases, the pump is swivelled out (towards $V_{g \max}$) until the pressure drop across the sensing orifice in the valve is restored.

$$\Delta P_{\text{orifice}} = P_{\text{pump}} - P_{\text{actuator}}$$

The setting range for ΔP is between 1.4 MPa and 2.5 MPa.

The standard differential pressure setting is 1.8 MPa. (Please state in clear text when ordering).

The stand-by pressure in zero stroke operation (sensing orifice plugged) is slightly above the ΔP setting.

(1) The sensing orifice (control block) is not included in the pump supply.

Characteristic LRDS

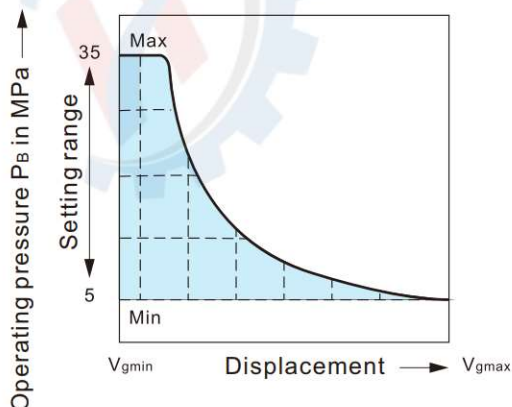

Circuit diagram LRDS

Size: 40...145

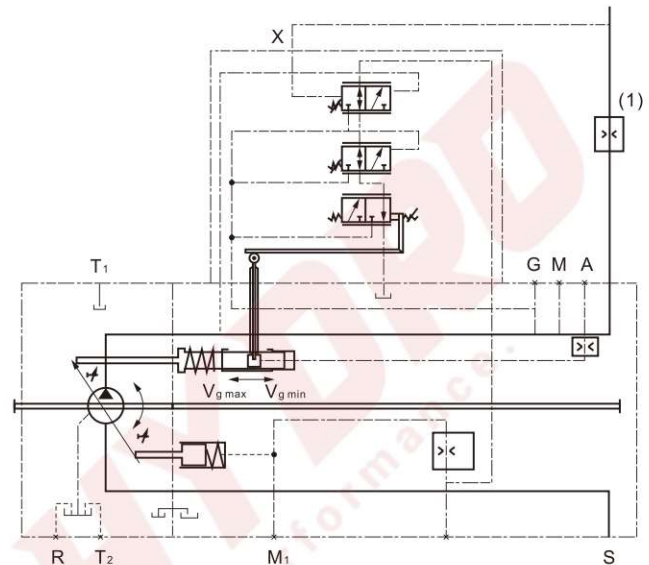

Size: 190...260

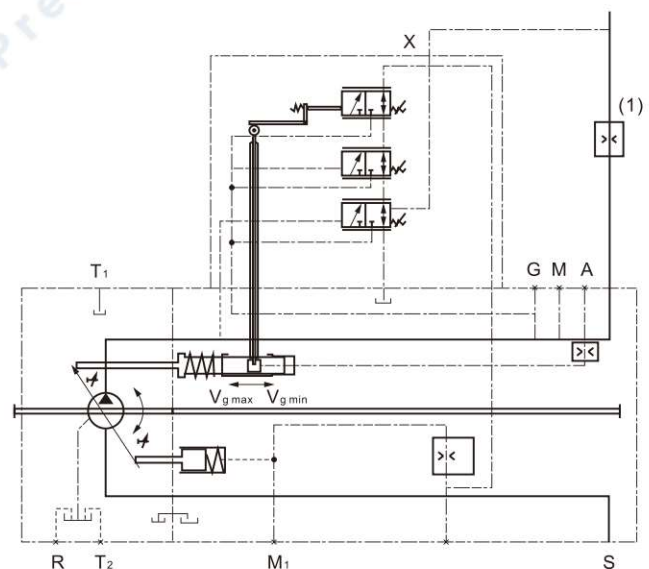

LR - Power Control

● LRS2 Power control with load sensing, electric override

This control option adds a proportional solenoid to override to the mechanically set load sensing pressure. The pressure differential change is proportional to the solenoid current.

Increasing current = smaller ΔP -setting

See following characteristic for details (example). Please consult us during the project planning phase.

For solenoid specification, see LE2 control

Characteristic LRS2

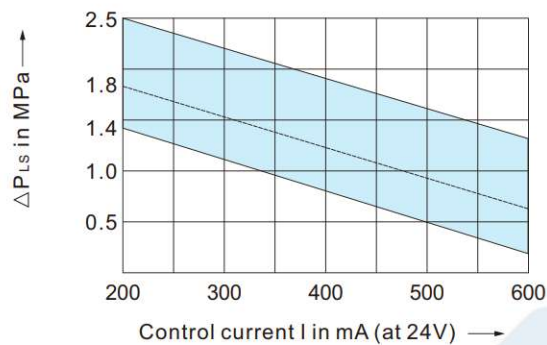

Circuit diagram LRS2

Size:40...145

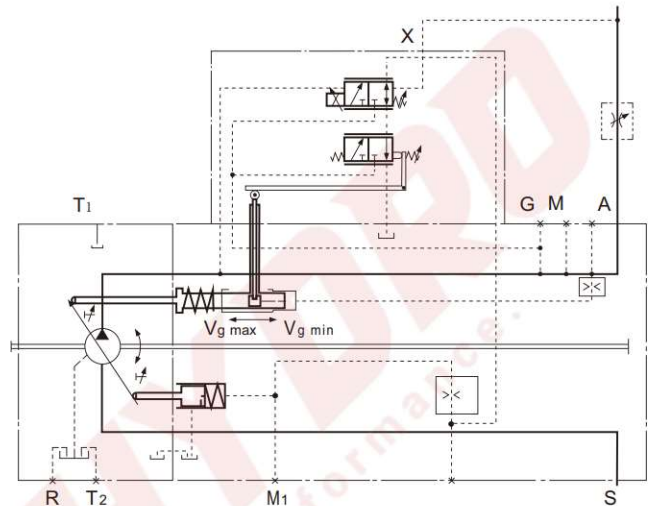

Size:190...260

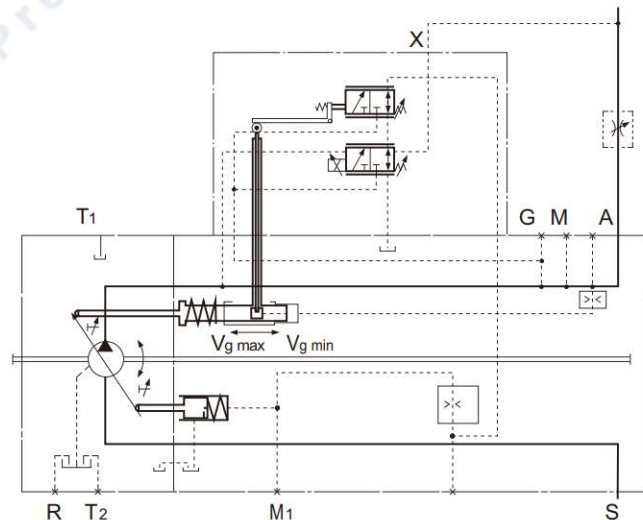

LR - Power Control

LR... Power control with stroke limiter

The stroke limiter can be used to vary or limit the displacement of the pump continuously over the whole control range. The displacement is set in LRH with the pilot pressure P_{st} (max. 4 MPa) applied to port Y or in LRU by the control current applied to the proportional solenoid. A DC current of 12V (U1) or 24V (U2) is required to control the proportional solenoid.

The power control overrides the stroke limiter control, i.e. below the hyperbolic power characteristic, the displacement is controlled by the control current or pilot pressure. When exceeding the power characteristic with a set flow or load pressure, the power control overrides and reduces the displacement following the hyperbolic characteristic.

To permit operation of the pump displacement control from its starting position $V_{g \max}$ to $V_{g \min}$, a minimum control pressure of 3 MPa is required for the electric stroke limiter LRU1/2 and the hydraulic stroke limiter LRH2/6.

The required control pressure is taken either from the load pressure, or from the externally applied control pressure at the G port.

To ensure functioning of the stroke limiter even at low operating pressure, port G must be supplied with external control pressure of approx. 3 MPa.

Note: If no external control pressure is connected at G, the shuttle valve must be removed.

LRH2/6 Hydraulic stroke limiter (positive characteristic)

Control from $V_{g \min}$ to $V_{g \max}$

With increasing pilot pressure the pump swivels to a higher displacement.

Start of control (at $V_{g \min}$), can be set from 0.4-1MPa.

State start of control in clear text in the order.

Starting position without control signal (pilot pressure):

- at operating pressure and external control pressure < 3 MPa: $V_{g \max}$
- at operating pressure or external control pressure > 3 MPa: $V_{g \min}$

Characteristic H6

Increase in pilot pressure ($V_{g \min} - V_{g \max}$) $\Delta P = 1.0 \text{ MPa}$

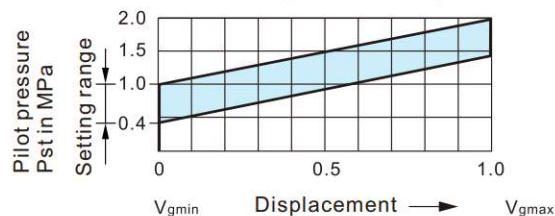

Characteristic H2

Increase in pilot pressure ($V_{g \min} - V_{g \max}$) $\Delta P = 2.5 \text{ MPa}$

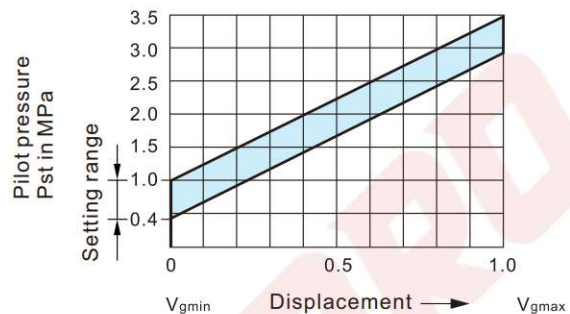

Circuit diagram LRS2

Size: 40...145

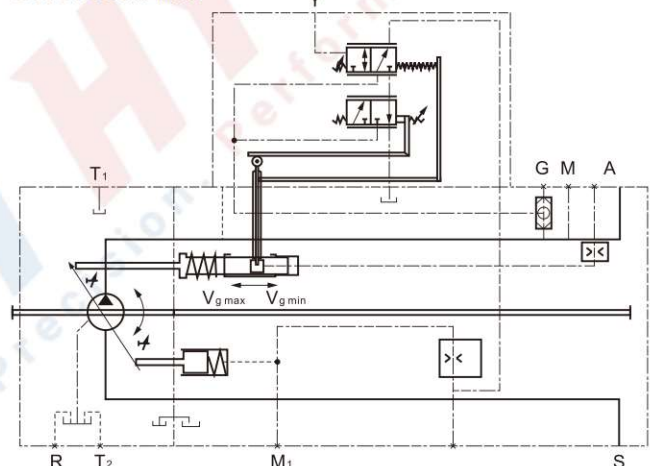

Size: 190...260

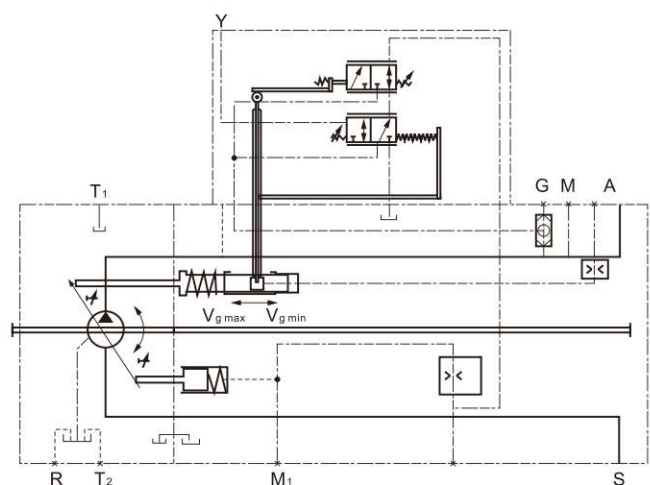

LR - Power Control

LRU1/2 Electric stroke limiter (positive characteristic)

Control from $V_{g \min}$ to $V_{g \max}$

With increasing control current the pump swivels to a higher displacement.

Technical data - solenoids

	LRU1	LRU2
Voltage	12V DC ($\pm 20\%$)	24V DC ($\pm 20\%$)
Control current		
Start of control	400mA	200mA
End of control	1200mA	600mA
Limiting current	1.54A	0.77A
Nominal resistance(at 20°C)	5.5Ω	22.7Ω
Dither frequency	100Hz	100Hz
Actuated time	100%	100%
Type of protection	IP65	

Starting position without control signal(control current):

- at operating pressure and external control pressure < 3 MPa: $V_{g \max}$
- at operating pressure or external control pressure > 3 MPa: $V_{g \min}$

Characteristic LRU1/2

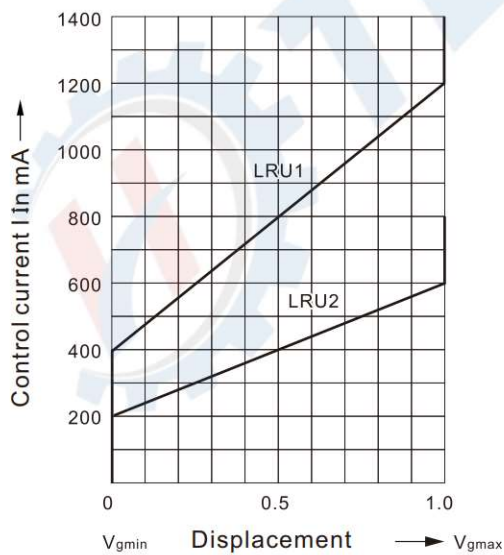

Circuit diagram LRU1/2

Size:40...145

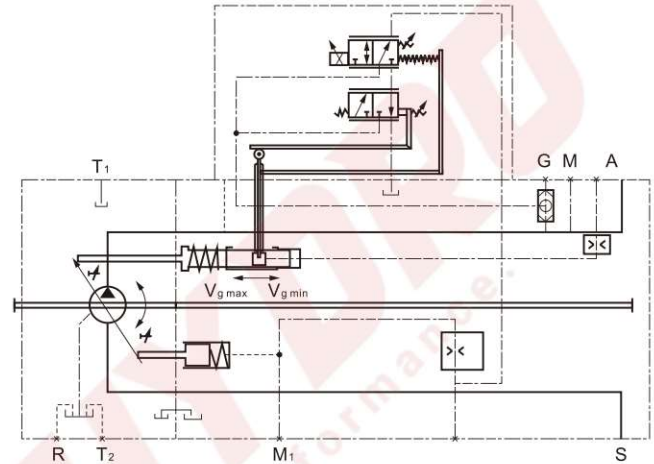

Size:190...260

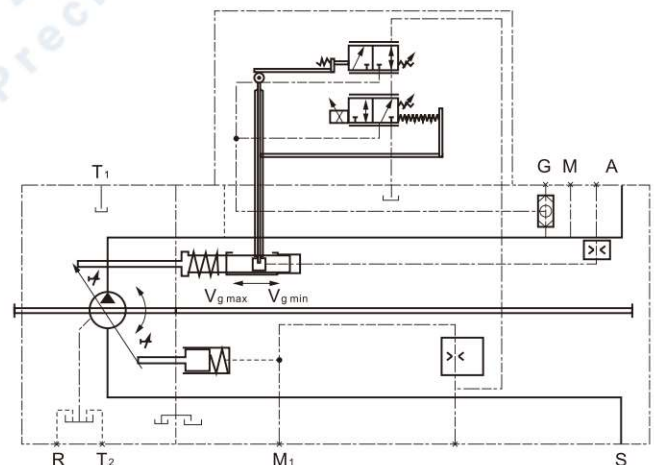

DR - Pressure Control

DR Pressure control

The pressure control keeps the pressure in a hydraulic system constant within its control range even under varying flow conditions. The variable pump only moves as much hydraulic fluid as is required by the actuators. If the operating pressure exceeds the setpoint set at the integral pressure control valve, the pump displacement is automatically swivelled back until the pressure deviation is corrected.

Starting position in depressurized state: $V_{g \max}$

Setting range from 5 to 35 Mpa.

Characteristic DR

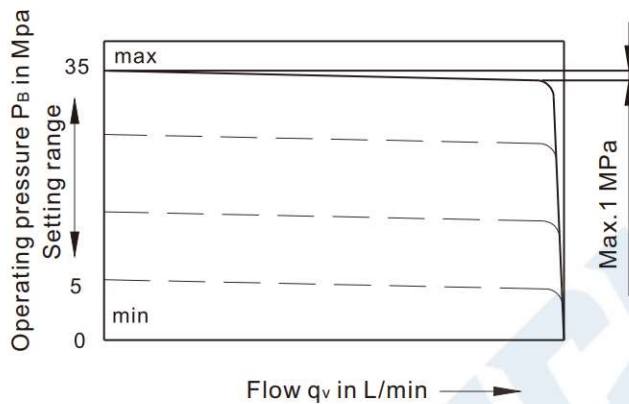

Circuit diagram DR

Size: 40...145

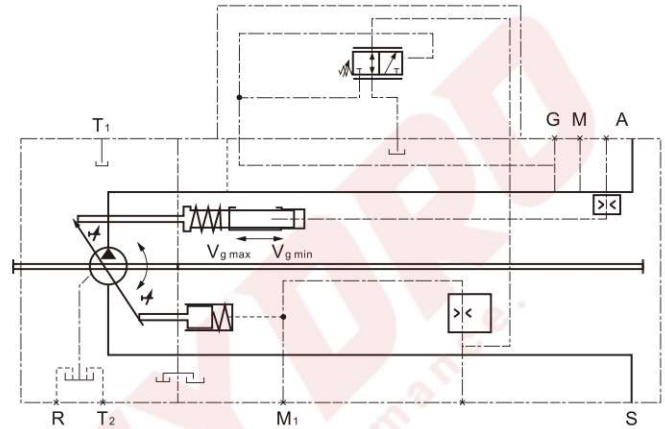

Size: 190...260

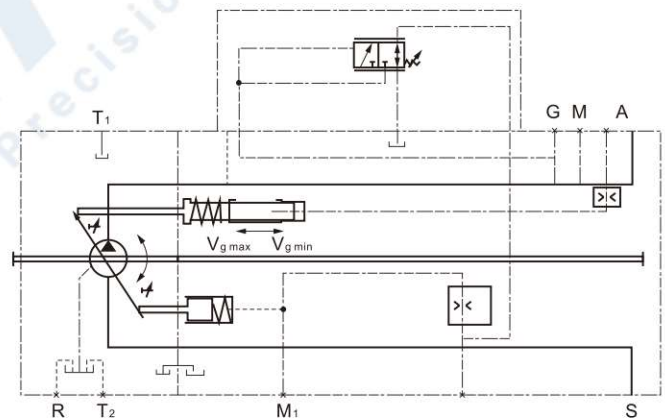

DR - Pressure Control

DRS Pressure control with load sensing

The load sensing control is a flow control option that operates as a function of the load pressure to regulate the pump displacement to match the actuator flow requirement.

The flow depends here on the cross section of the external sensing orifice (1) fitted between the pump outlet and the actuator. The flow is independent of the load pressure below the pressure cut-off setting and within the control range of the pump.

The sensing orifice is usually a separately arranged load sensing directional valve (control block). The position of the directional valve piston determines the opening cross section of the sensing orifice and thus the flow of the pump.

The load sensing control compares pressure before and after the sensing orifice and maintains the pressure drop across the orifice (differential pressure ΔP) and with it the pump flow constant.

If the differential pressure ΔP increases at sensing orifice, the pump is swivelled back (towards $V_{g \min}$), and, if the differential pressure ΔP decreases, the pump is swivelled out (towards $V_{g \max}$) until the pressure drop across the sensing orifice in the valve is restored.

$$\Delta P_{\text{orifice}} = P_{\text{pump}} - P_{\text{actuator}}$$

The setting range for ΔP is between 1.4MPa and 2.5MPa.

The standard differential pressure setting is 1.8MPa. (Please state in clear text when ordering).

The stand-by pressure in zero stroke operation (sensing orifice plugged) is slightly above the ΔP setting.

(1) The sensing orifice (control block) is not included in the pump supply.

Characteristic DRS

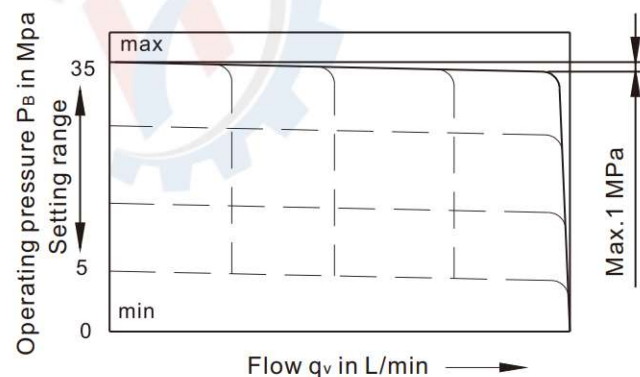

Circuit diagram DRS

Size:40...145

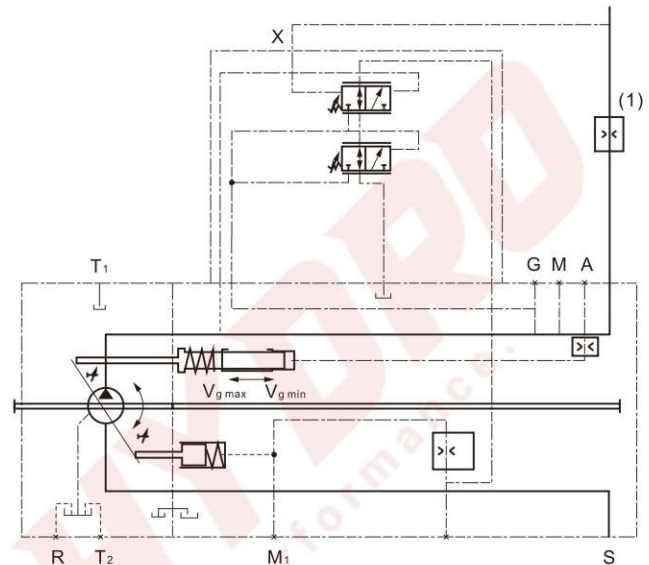

Size:190...260

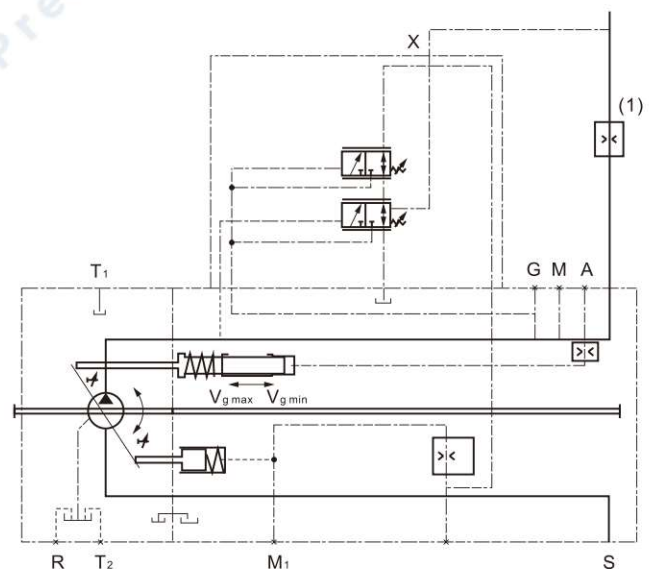

■ EP - Electric Control With Proportional Solenoid

With the electric control with proportional solenoid, the pump displacement is adjusted proportionally to the solenoid current, resulting in a magnetic control force, acting directly onto the control spool that pilots the pump control piston.

Control from $V_{g \min}$ go $V_{g \max}$

With increasing control current the pump swivels to a higher displacement.

Starting position without control signal (control current):

- at operating pressure and external control pressure $< 3\text{MPa}$: $V_{g \max}$

- at operating pressure and external control pressure $> 3\text{MPa}$: $V_{g \min}$

A control pressure of 3 MPa is required to swivel the pump from its starting position $V_{g \max}$ to $V_{g \min}$.

The required control pressure is taken either from the load pressure, or from the externally applied control pressure at port G.

To ensure the control even at low operating pressure $< 3\text{MPa}$ the port G must be supplied with an external control pressure of approx. 3 MPa.

Note:

If no external control pressure is connected at G, the shuttle valve must be removed.

Note:

Install pump with EP control in the oil tank only when using mineral hydraulic oils and an oil temperature in the tank of max. 80°C.

Characteristic EP1/2

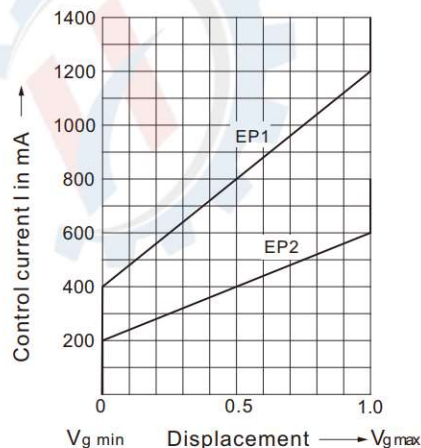

Technical data - solenoids

	Ep1	Ep2
Voltage	12V DC ($\pm 20\%$)	24V DC ($\pm 20\%$)
Control current		
Start of control at $V_{g \min}$	400mA	200mA
End of control at $V_{g \max}$	1200mA	600mA
Limiting current	1.54A	0.77A
Nominal resistance(at 20°C)	5.5Ω	22.7Ω
Dither frequency	100Hz	100Hz
Actuated time	100%	100%
Type of protection	IP65	

Circuit diagram EP1/2

Size:40...145

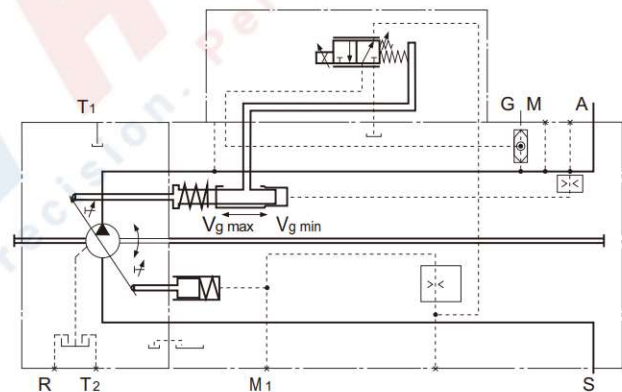

Size:190...260

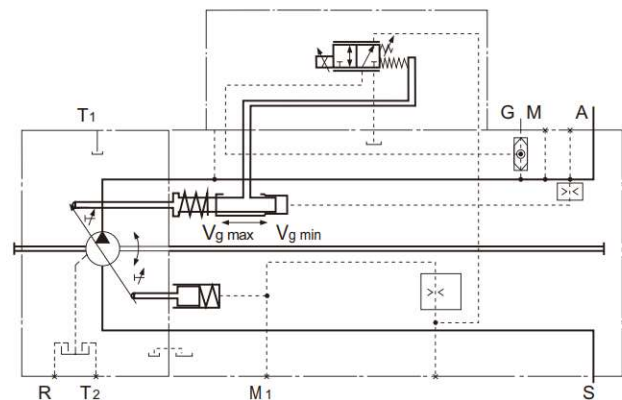

■ EP - Electric Control With Proportional Solenoid

● EP.D Electric control with pressure cut-off

The pressure cut-off corresponds to a pressure control which adjusts the pump displacement back to $V_{g\ min}$ when the pressure setting is reached.

This function overrides the EP control, i.e. the control current related displacement control is functional below the pressure setting.

The valve for the pressure cut-off is integrated in the control case and is set to a fixed specified pressure value at the factory.

Setting range from 5 to 35 Mpa.

Pressure cut-off characteristic D

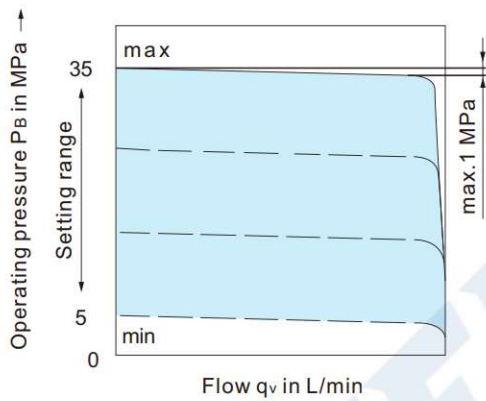

Circuit diagram EP.D

Size:40...145

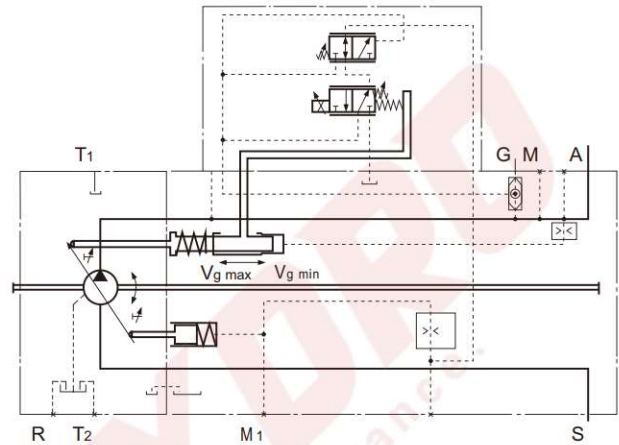

Size:190...260

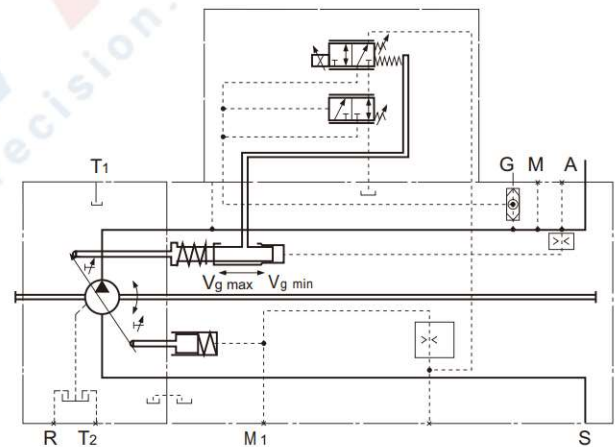

Installation dimensions Size 40

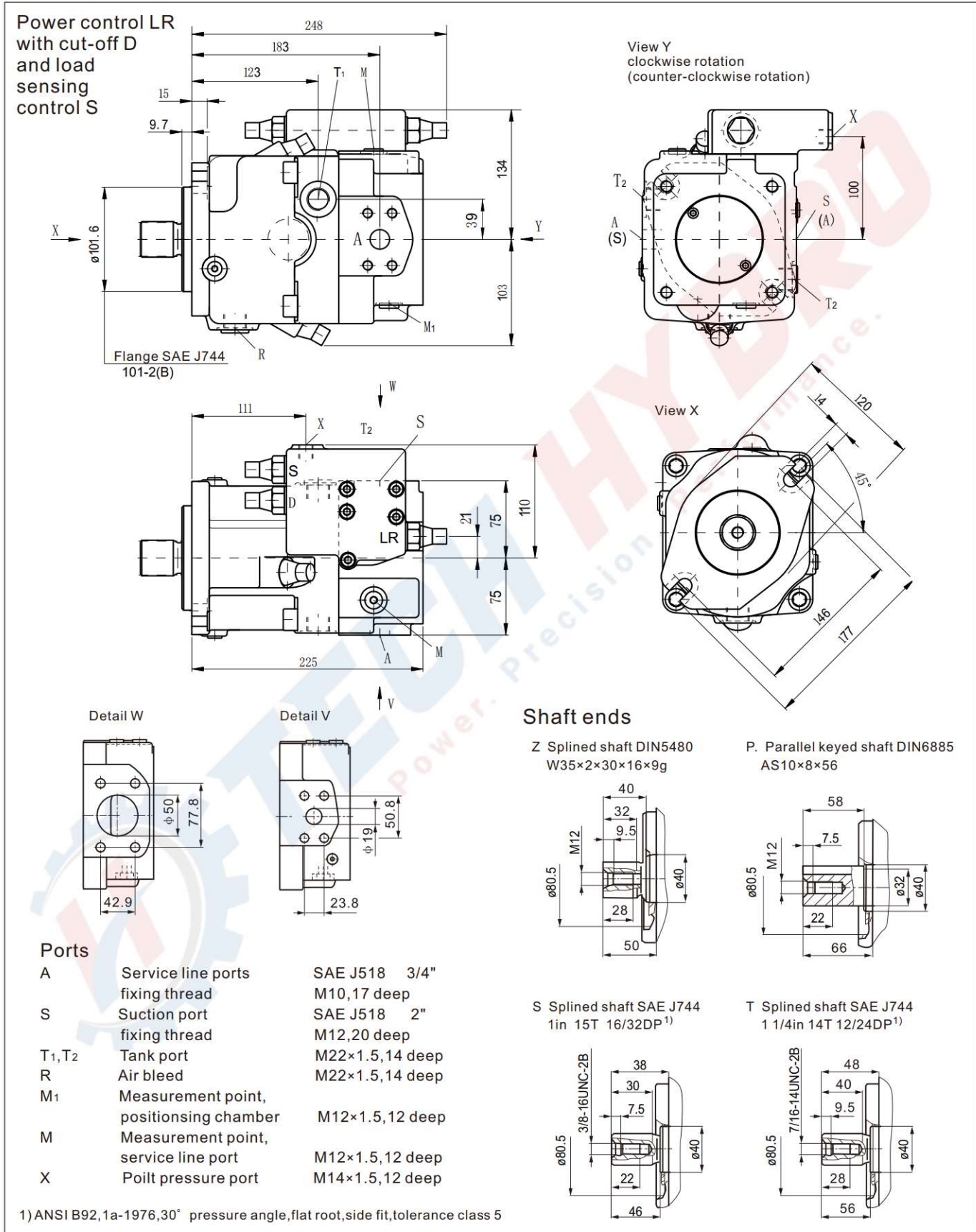

Installation dimensions Size 40

LRDH2/LRDH6:

Power control with pressure cut-off and hydraulic stroke limiter(positive characteristic)

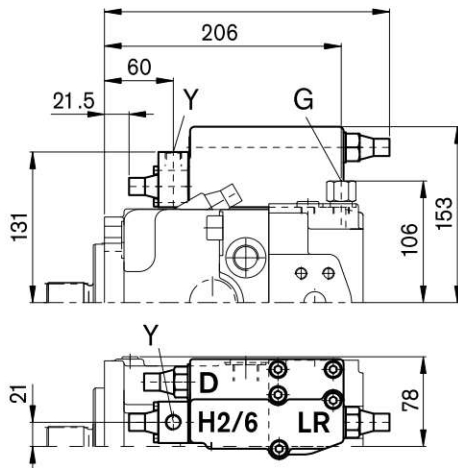

Y Poilt pressure port M14×1.5,12 deep

LRDU1/LRDU2:

Power control with pressure cut-off and electric stroke limiter(positive characteristic)

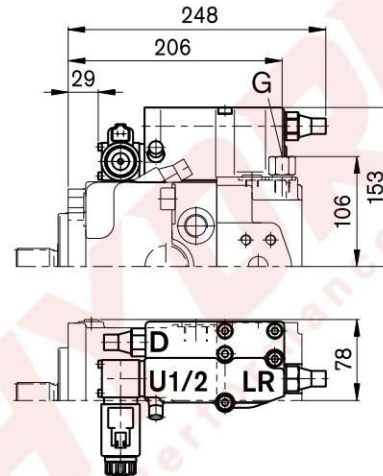

DRS:

Pressure control with load sensing control

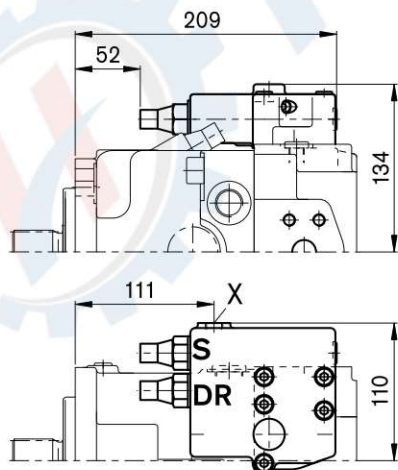

Installation dimensions Size 60

Power control LR with cut-off D and load sensing control S

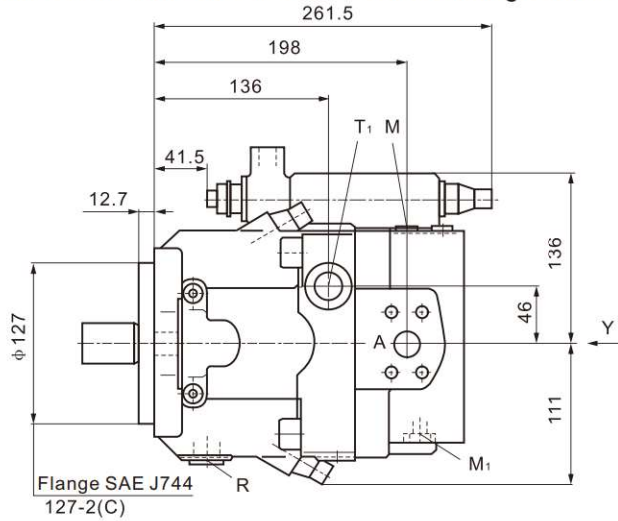

View Y
clockwise rotation
(counter-clockwise rotation)

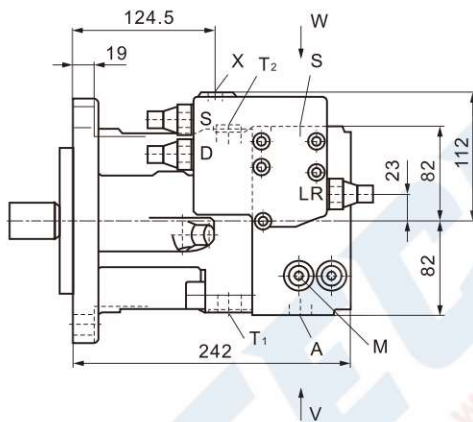
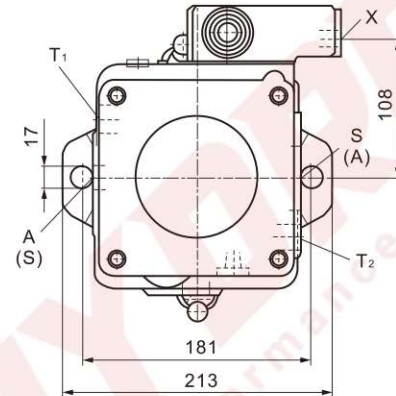

Detail W

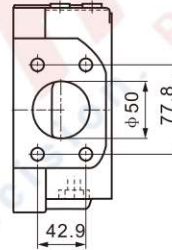

Detail V

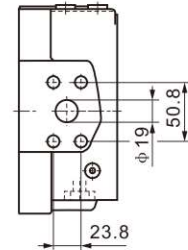

Shaft ends

Z Splined shaft DIN5480
W35×2×30×16×9g

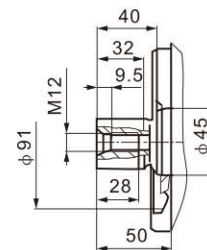

P. Parallel keyed shaft DIN6885
AS10×8×56

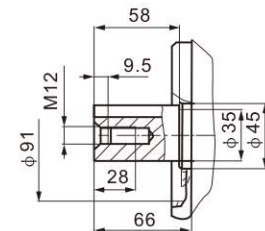

S Splined shaft SAE J744
1 1/4in 14T 12/24DP¹⁾

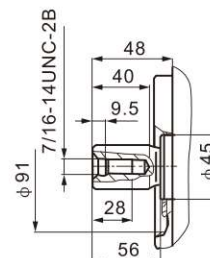

T Splined shaft SAE J744
1 3/8in 21T 16/32DP¹⁾

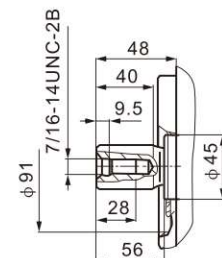

Ports

A	Service line ports fixing thread	SAE J518 3/4" M10,17 deep
S	Suction port fixing thread	SAE J518 2" M12,20 deep
T ₁ ,T ₂	Tank port	M22×1.5,14 deep
R	Air bleed	M22×1.5,14 deep
M ₁	Measurement point, positioning chamber	M12×1.5,12 deep
M	Measurement point, service line port	M12×1.5,12 deep
X	Poilt pressure port	M14×1.5,12 deep

1) ANSI B92,1a-1976,30° pressure angle,flat root,side fit,tolerance class 5

■ Installation dimensions Size 60

LRDH2/LRDH6:

Power control with pressure cut-off and hydraulic stroke limiter(positive characteristic)

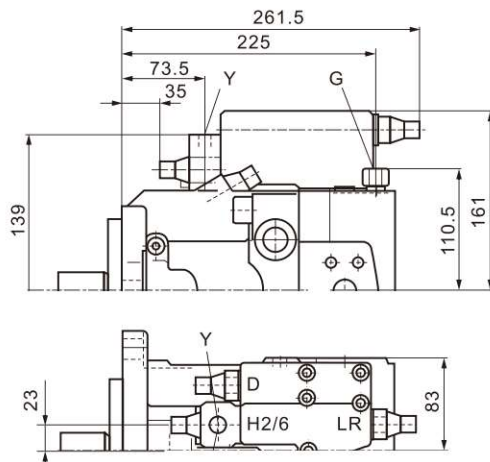

Y Poilt pressure port M14×1.5,12 deep

LRDU1/LRDU2:

Power control with pressure cut-off and electric stroke limiter(positive characteristic)

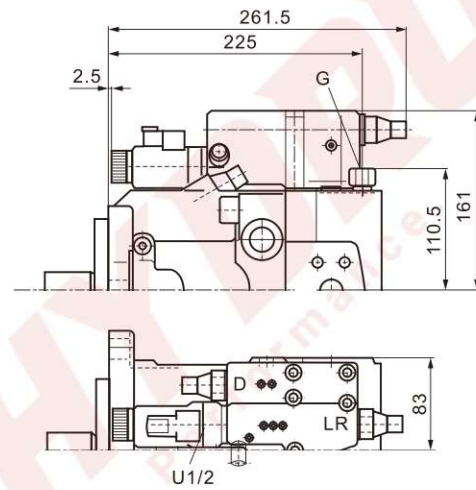

DRS:

Pressure control with load sensing control

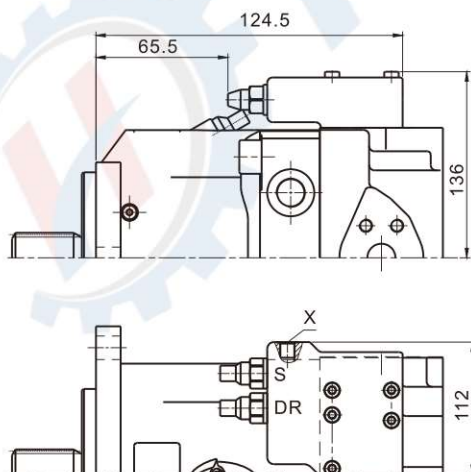

Installation dimensions Size 75

Power control LR with cut-off D and load sensing control S

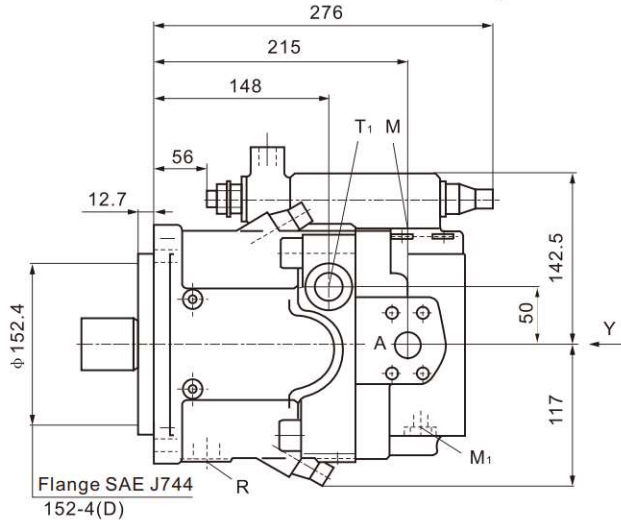

View Y
clockwise rotation
(counter-clockwise rotation)

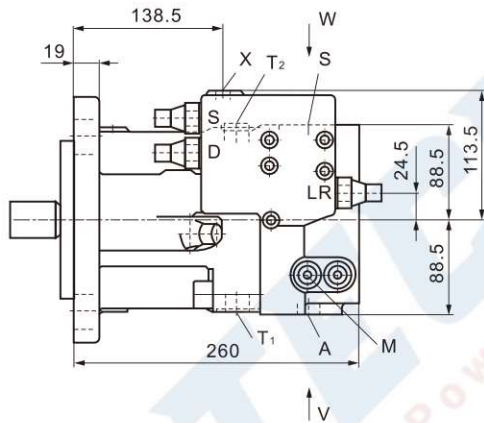
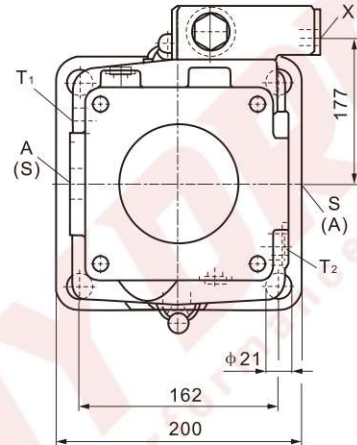

Detail W

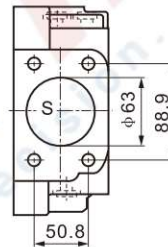

Detail V

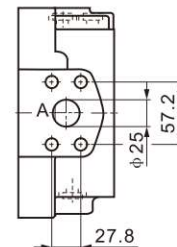

Shaft ends

Z Splined shaft DIN5480
W40×2×30×18×9g

P Parallel keyed shaft DIN6885
AS12×8×80

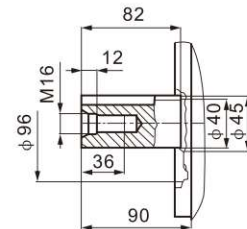
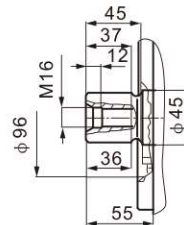

S Splined shaft SAE J744
1 1/4in 14T 12/24DP¹⁾

T Splined shaft SAE J744
1 3/8in 21T 16/32DP¹⁾

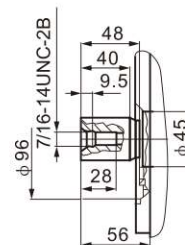
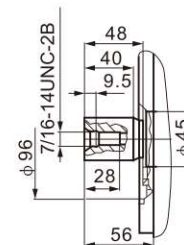

Ports

A	Service line ports fixing thread	SAE J518 1" M12,17 deep
S	Suction port fixing thread	SAE J518 2 1/2" M12,17 deep
T ₁ ,T ₂	Tank port	M22×1.5,14 deep
R	Air bleed	M22×1.5,14 deep
M ₁	Measurement point, positioning chamber	M12×1.5,12 deep
M	Measurement point, service line port	M12×1.5,12 deep
X	Poilt pressure port	M14×1.5,12 deep

1) ANSI B92,1a-1976,30° pressure angle,flat root,side fit,tolerance class 5

■ Installation dimensions Size 75

LRDH2/LRDH6:

Power control with pressure cut-off and hydraulic stroke limiter(positive characteristic)

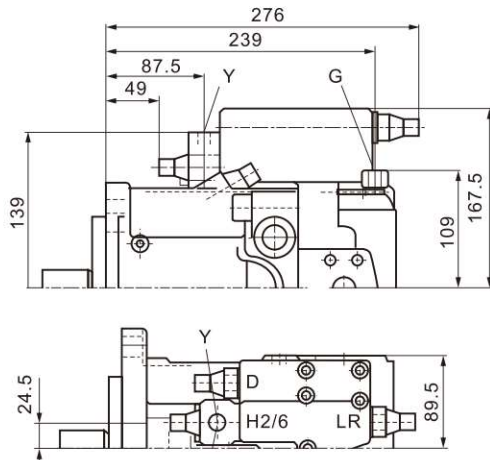

LRDU1/LRDU2:

Power control with pressure cut-off and electric stroke limiter(positive characteristic)

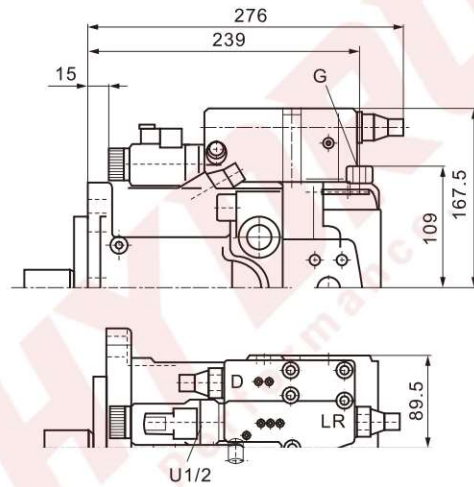

Y	Poilt pressure port	M14×1.5,12 deep
G	Port for control pressure (controller)	M14×1.5,12 deep

DRS:

Pressure control with load sensing control

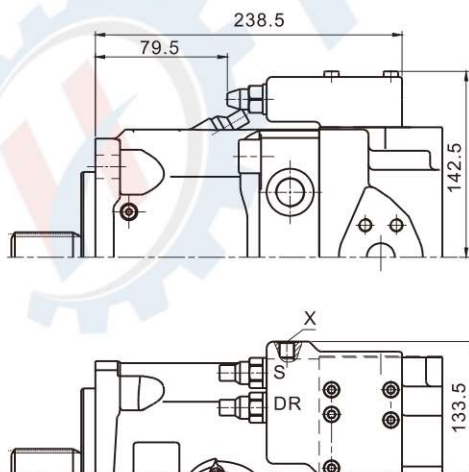

Installation dimensions Size 95,115

Power control LR with cut-off D and load sensing control S

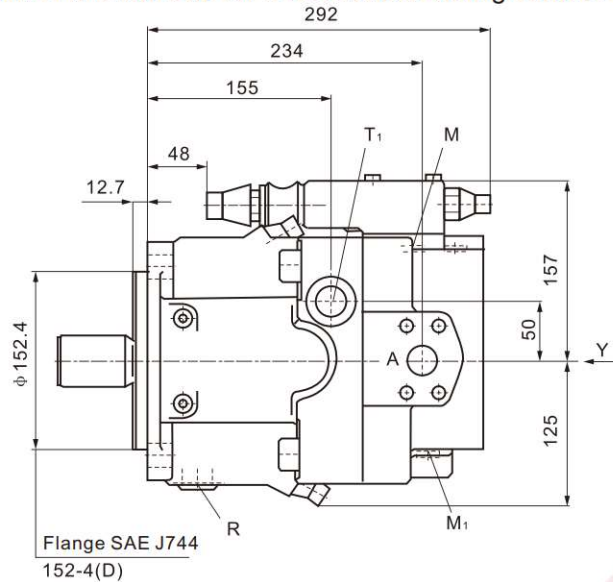

View Y
clockwise rotation
(counter-clockwise rotation)

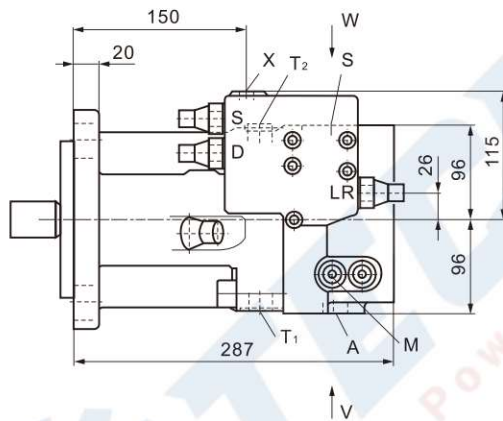
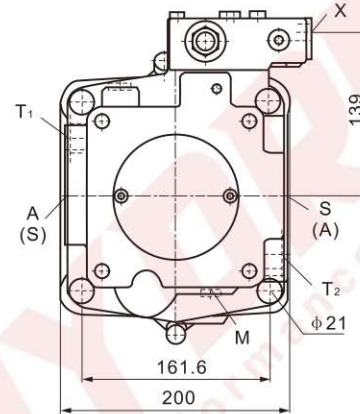

Detail W

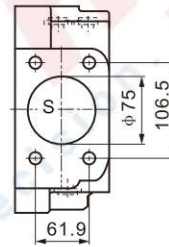

Detail V

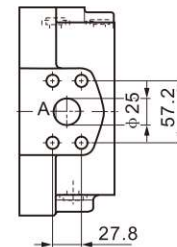

Shaft ends

Z Splined shaft DIN5480
W45×2×30×21×9g

P Parallel keyed shaft DIN6885
AS14×9×80

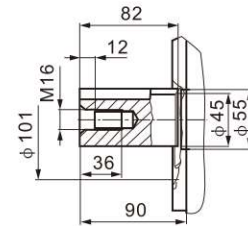
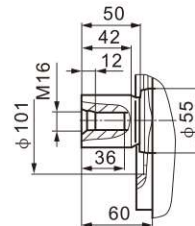

S Splined shaft SAE J744
1 3/4in 13T 8/16DP¹⁾

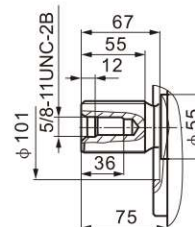

Ports

A	Service line ports fixing thread	SAE J518 1" M12,17 deep
S	Suction port fixing thread	SAE J518 3" M12,17 deep
T ₁ , T ₂	Tank port	M26×1.5,16 deep
R	Air bleed	M26×1.5,16 deep
M ₁	Measurement point, positioning chamber	M12×1.5,12 deep
M	Measurement point, service line port	M12×1.5,12 deep
X	Poilt pressure port	M14×1.5,12 deep

1) ANSI B92,1a-1976,30° pressure angle,flat root,side fit,tolerance class 5

Installation dimensions Size 95,115

LRDH2/LRDH6:

Power control with pressure cut-off and hydraulic stroke limiter(positive characteristic)

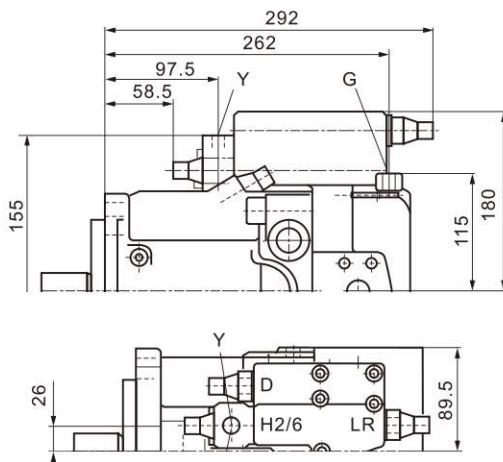

Y	Poilt pressure port	M14×1.5,12 deep
G	Port for control pressure (controller)	M14×1.5,12 deep

LRDU1/LRDU2:

Power control with pressure cut-off and electric stroke limiter(positive characteristic)

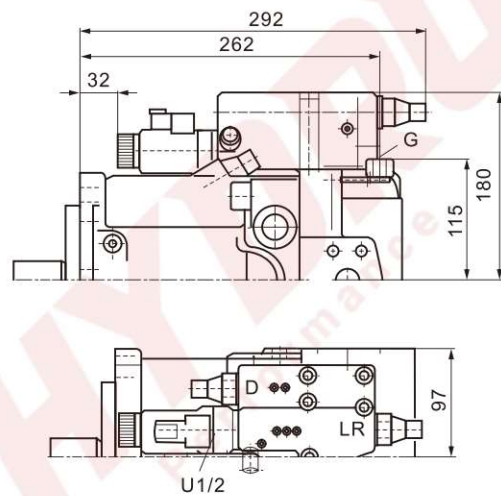

DRS:

Pressure control with load sensing control

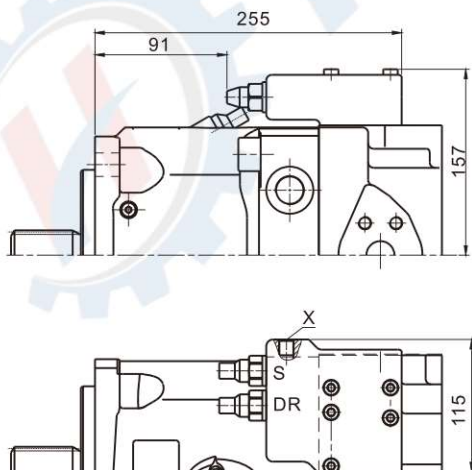

EP1D/EP2D:

Electric control with proportional solenoid and pressure cut-off

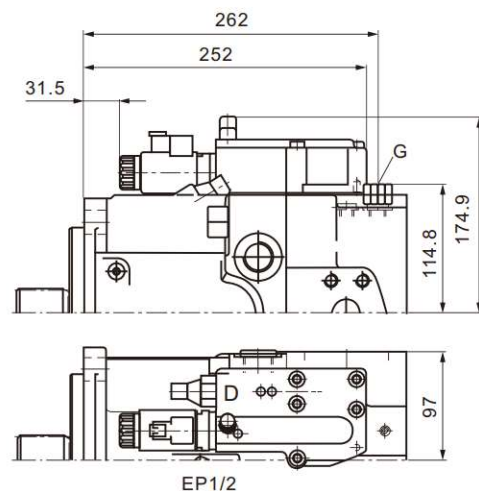

■ Installation dimensions Size 95,115

LE2S2:

Power control with electric override(negative)
and load sensing control,override

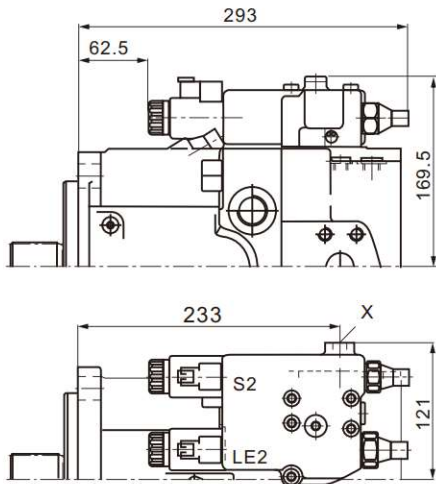

Installation dimensions Size 130,145

Power control LR with cut-off D and load sensing control S

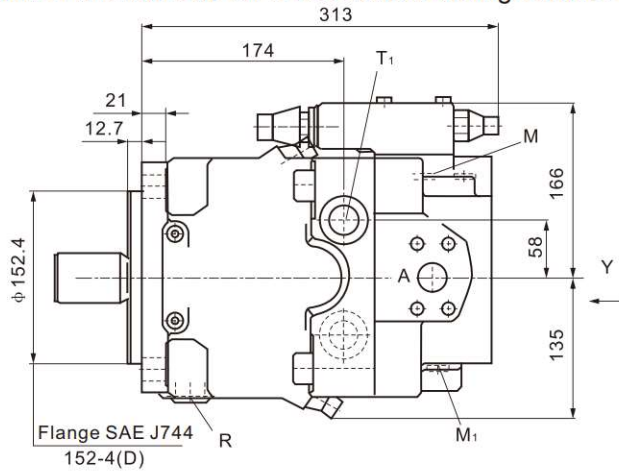

View Y
clockwise rotation
(counter-clockwise rotation)

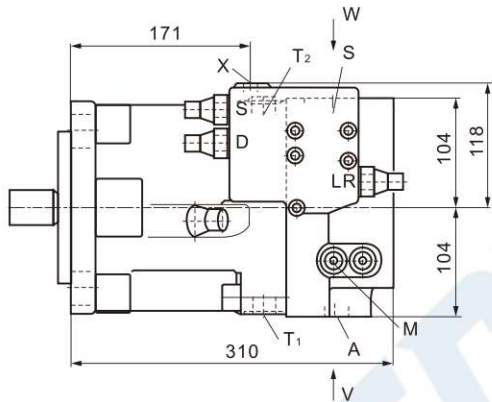
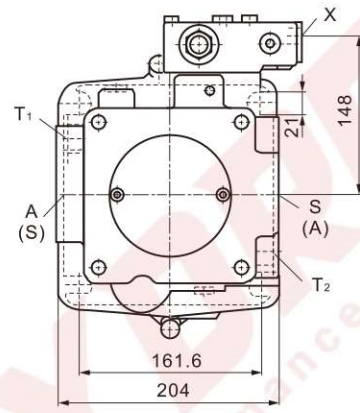

Without change pump
Detail W

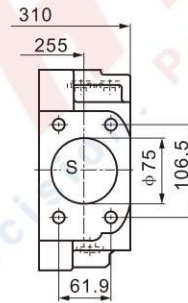

Detail V

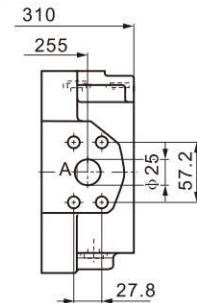

With change pump
Detail W

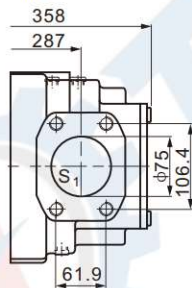

Detail V

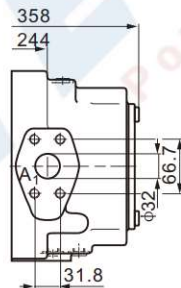

Shaft ends

Z Splined shaft DIN5480
W50×2×30×24×9g

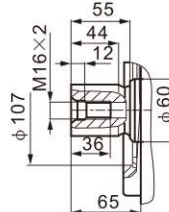

P Parallel keyed shaft DIN6885
AS14×9×80

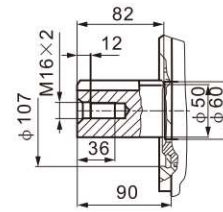

S Splined shaft SAE J744
1 3/4in 13T 8/16DP¹⁾

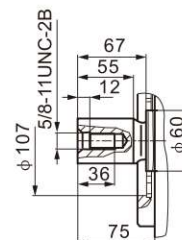

Ports

A	Service line port fixing thread	SAE J518 1" M12,17 deep
A1	Service line port fixing thread	SAE J518 1 1/4" M14,19 deep
S,S1	Suction port fixing thread	SAE J518 3" M12,17 deep
T ₁ ,T ₂	Tank port	M26×1.5,16 deep
R	Air bleed	M26×1.5,16 deep
M ₁	Measurement point, positioning chamber	M12×1.5,12 deep
M	Measurement point, service line port	M12×1.5,12 deep
X	Poilt pressure port	M14×1.5,12 deep

1) ANSI B92,1a-1976,30° pressure angle,flat root,side fit,tolerance class 5

Installation dimensions Size 130,145

LRDH2/LRDH6:

Power control with pressure cut-off and hydraulic stroke limiter(positive characteristic)

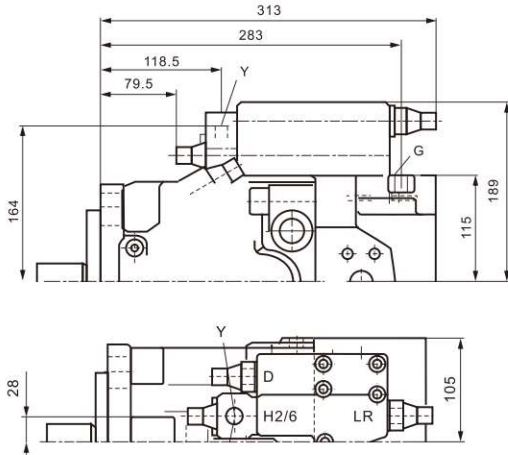

Y	Poilt pressure port	M14×1.5,12 deep
G	Port for control pressure (controller)	M14×1.5,12 deep

LRDU1/LRDU2:

Power control with pressure cut-off and electric stroke limiter(positive characteristic)

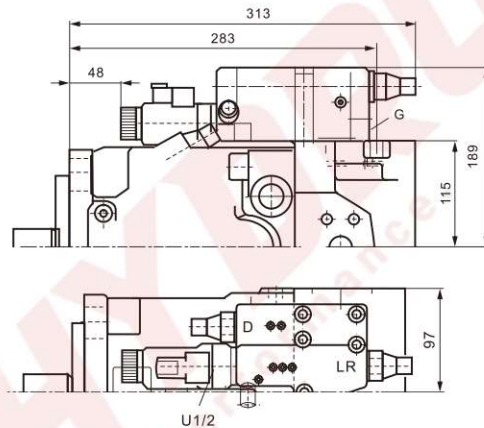

DRS:

Pressure control with load sensing control

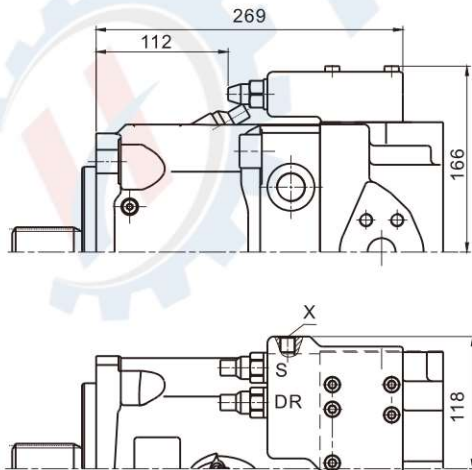

EP1D/EP2D:

Electric control with proportional solenoid and pressure cut-off

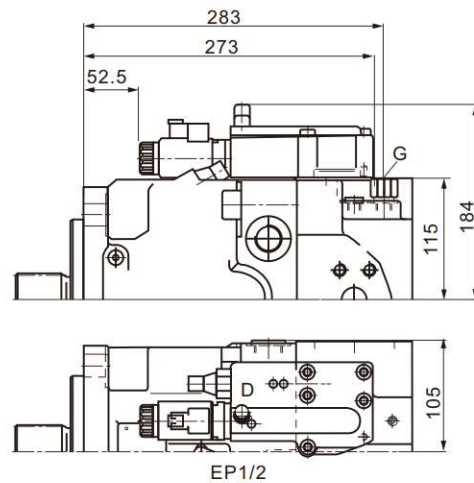

■ Installation dimensions Size 130,145

LE2S2:

Power control with electric override(negative)
and load sensing control,override

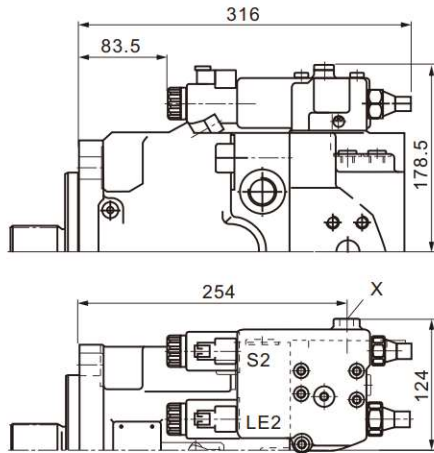

Installation dimensions Size 190

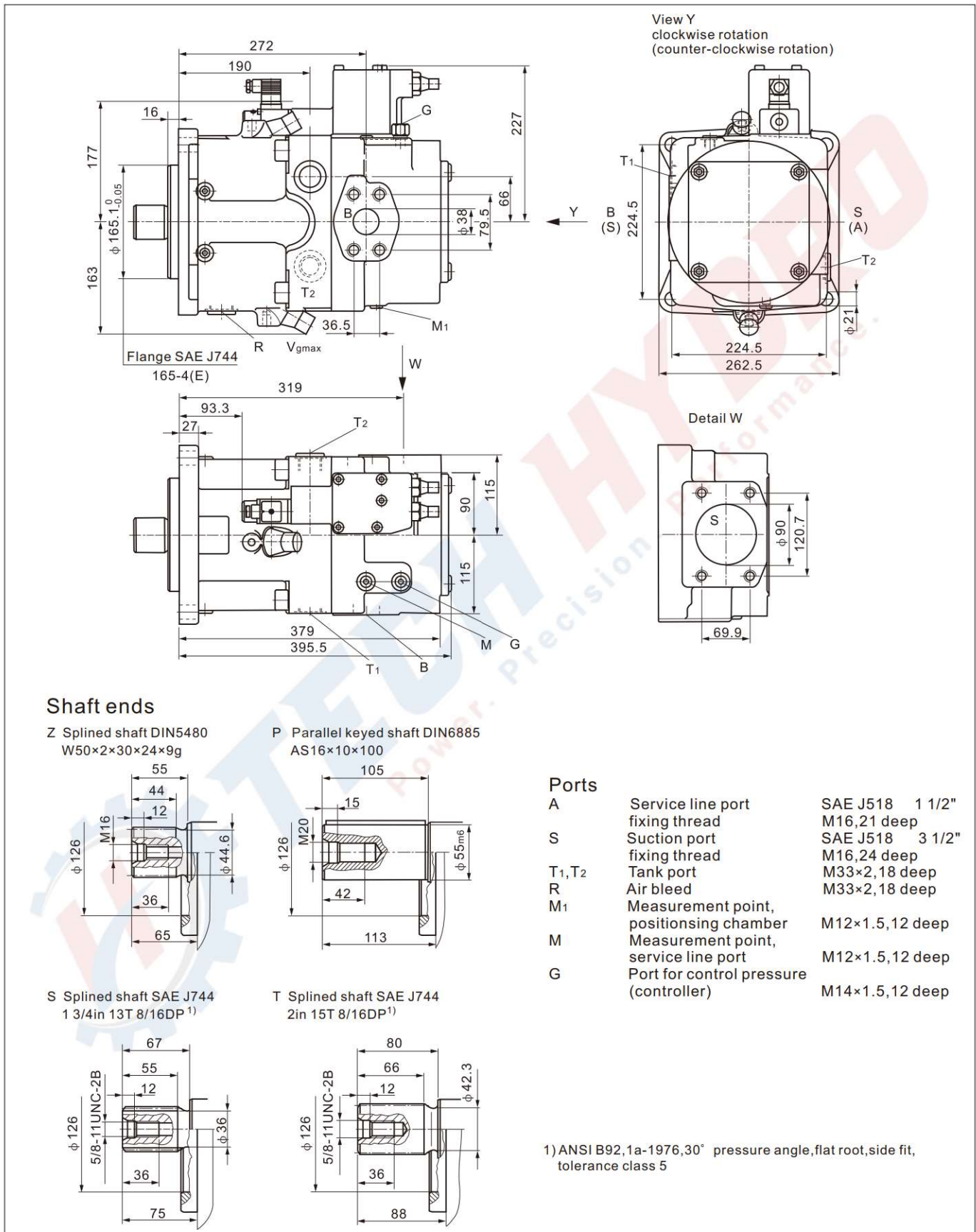

Installation dimensions Size 190

LRDH2/LRDH6:

Power control with pressure cut-off and hydraulic stroke limiter(positive characteristic)

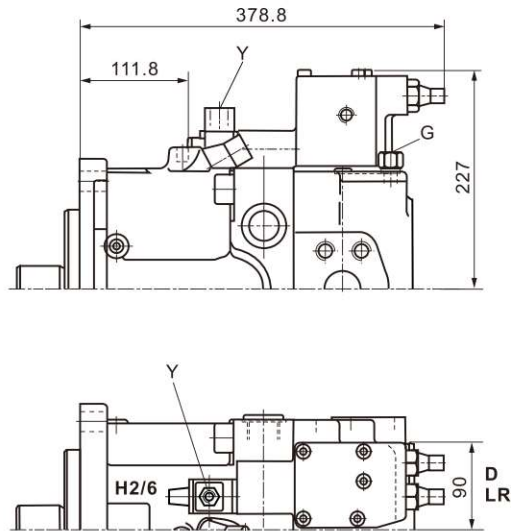

Y Poilt pressure port M14×1.5,12 deep

LRDU1/LRDU2:

Power control with pressure cut-off and electric stroke limiter(positive characteristic)

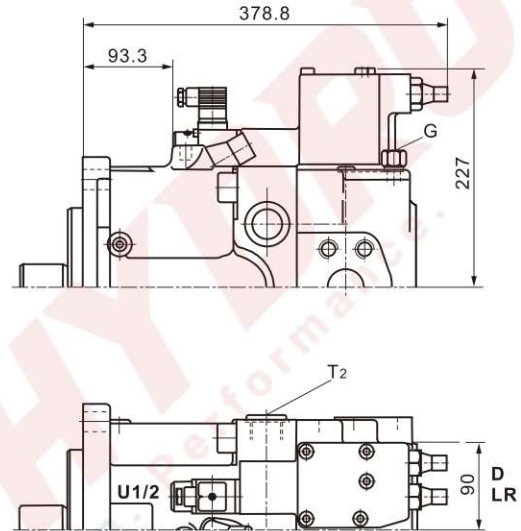

LE2S2:

Power control with electric override(negative) and load sensing control,override

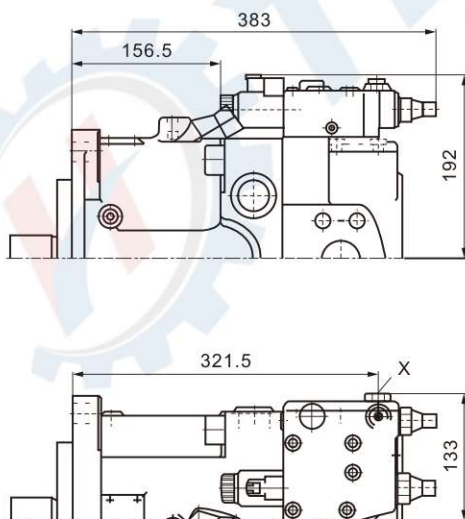

Installation dimensions Size 260

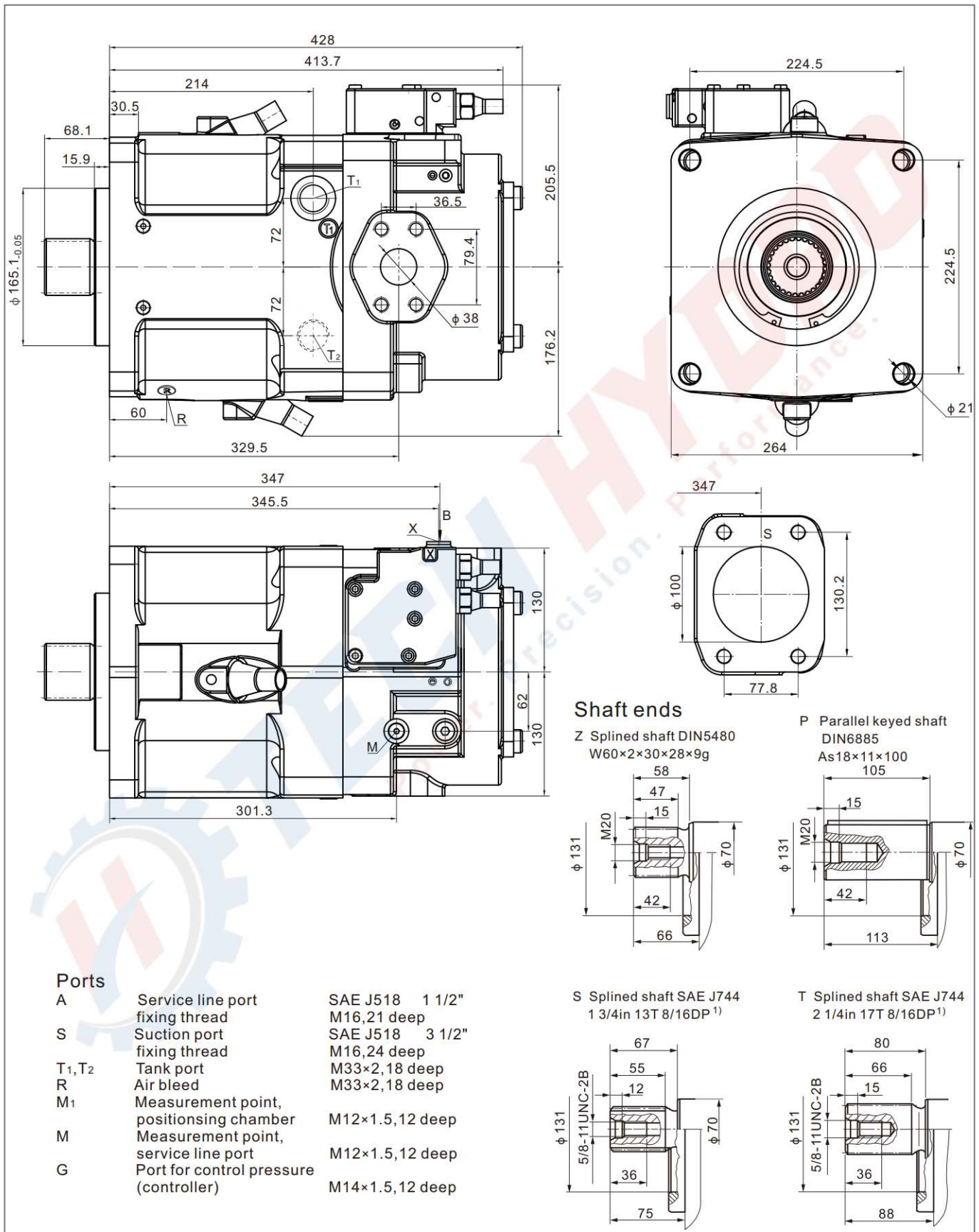

Installation dimensions Size 260

LRDH2/LRDH6:

Power control with pressure cut-off and hydraulic stroke limiter(positive characteristic)

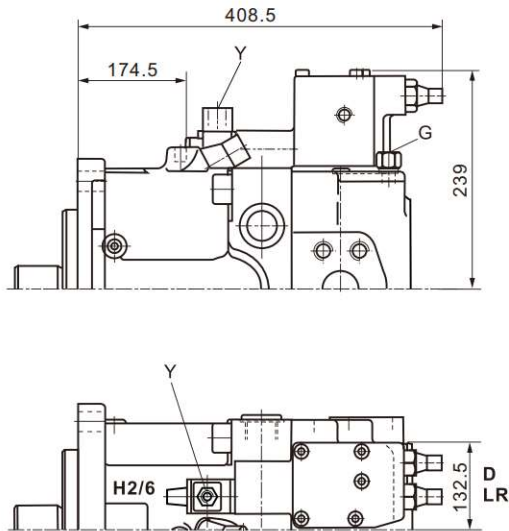

Y Poilt pressure port M14×1.5,12 deep

LRDU1/LRDU2:

Power control with pressure cut-off and electric stroke limiter(positive characteristic)

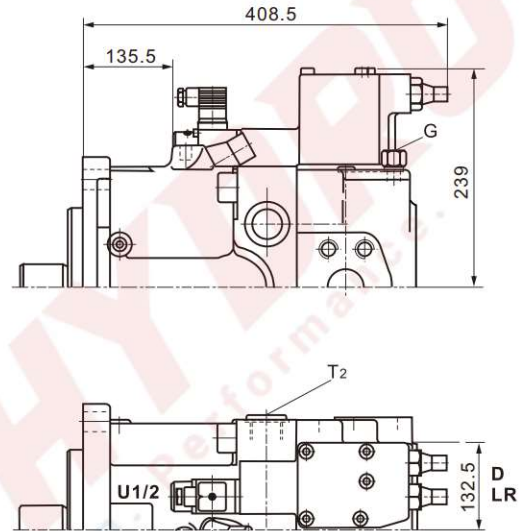

LE2S2:

Power control with electric override(negative) and load sensing control,override

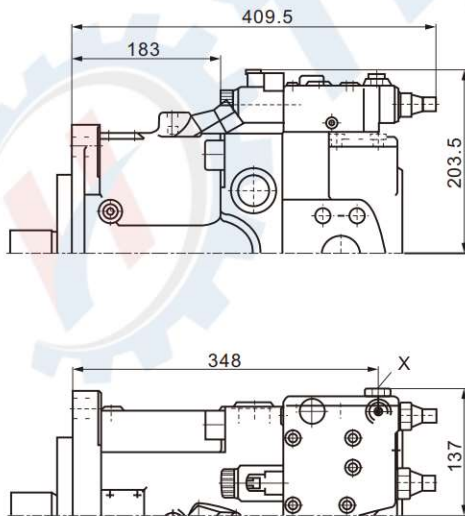

Through Drive Dimensions

Flange SAE J744-82-2(A)
Coupler for splined shaft acc.to ANSI B92,1a-1976

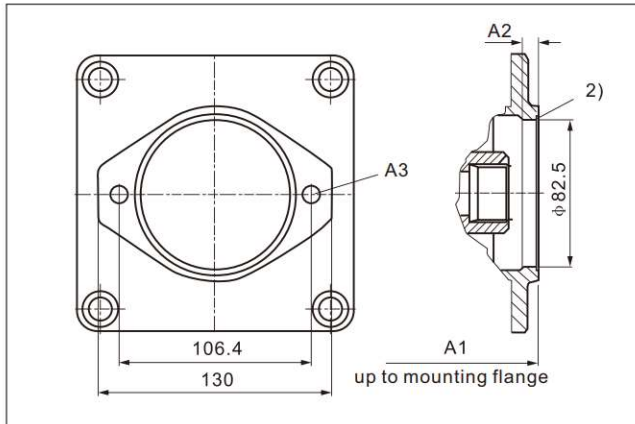

5/8in 9T 16/32DP¹⁾ (SAE J744-16-4(A)) K01
3/4in 11T 16/32DP¹⁾ (SAE J744-19-4(A-B)) K52

Size	A1		A2	A3
	K01	K52		
40	240	240	8	M10;15 deep
60	257	257	-	M10;15 deep
75	275	275	-	M10;15 deep
95/115	306	306	-	M10;12.5 deep
130/145	329	329	-	M10;12.5 deep
130/145*	363	363	-	M10;12.5 deep
190*	394	394	-	M10;13 deep
260*	427.3	427.3	-	M10;13 deep

*) Version with charge pump

Flange SAE J744-101-2(B)
Coupler for splined shaft acc.to ANSI B92,1a-1976

Coupler for splined shaft acc.to DIN 5480

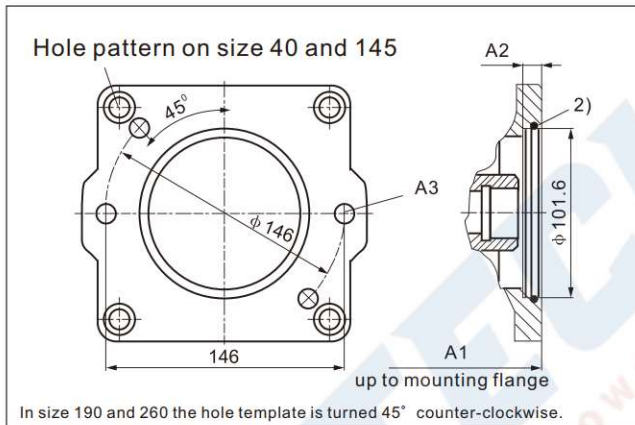

7/8in 13T 16/32DP¹⁾ (SAE J744-22-4(B)) K02
1in 15T 16/32DP¹⁾ (SAE J744-25-4(B-B)) K04

W35×2×30×16×9g

K79

Size	A1			A2	A3
	K02	K04	K79		
40	244	244		10	M12;19 deep
60	261	261	261	10	M12;19 deep
75	279	279		10	M12;19 deep
95/115	303	303	303	10	M12;16 deep
130/145	326	326	326	10	M12;16 deep
130/145*	360	360	360	10	M12;16 deep
190*	404	404	394	-	M12;15 deep
260*	437.5	437.5	437.5	-	M12;15 deep

*) Version with charge pump

Flange SAE J744-127-2(C)
Coupler for splined shaft acc.to ANSI B92,1a-1976

Coupler for splined shaft acc.to DIN 5480

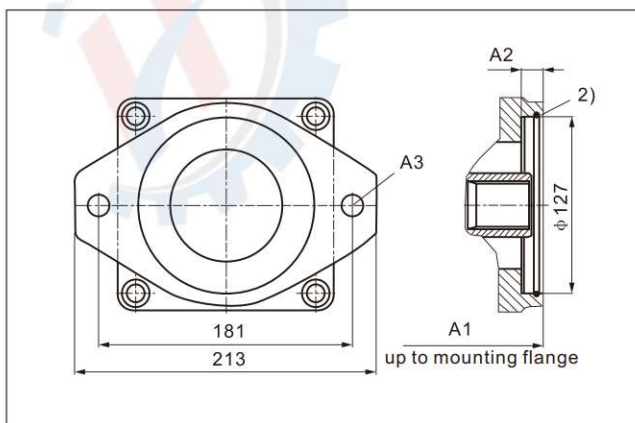

1 1/4in 14T 12/24DP¹⁾ (SAE J744-32-4(C)) K07
1 1/2in 17T 12/24DP¹⁾ (SAE J744-38-4(C-C)) K24

W30×2×30×14×9g

K80

W35×2×30×16×9g

K61

Size	A1		A2		A3
	K07	K24	K80	K61	
60	272	-	265	265	13 M16,20 deep
75	290	-	283	283	13 M16,20 deep
95/115	318	318	318	318	13 M16,20 deep
130/145	330	330	330	330	13 M16,20 deep
130/145*	364	364	364	364	13 M16,20 deep
190*	400	400	400	400	13 M16,19 deep

*) Version with charge pump

NOTE: The mounting flange may be turned through 90°. Standard position as illustrated. Please state in clear text if required.

1) 30° pressure angle, flat root, side fit, tolerance class 5
2) O-ring included in the delivery contents

Through Drive Dimensions

Flange SAE J744-152-4(A)
Coupler for splined shaft acc.to ANSI B92,1a-1976
Coupler for splined shaft acc.to DIN 5480

1 1/4in 14T 12/24DP¹⁾ (SAE J744-32-4(C)) K86
1 3/4in 13T 8/16DP¹⁾ (SAE J744-44-4(D)) K17
W40×2×30×18×9g K81
W45×2×30×21×9g K82
W50×2×30×24×9g K83

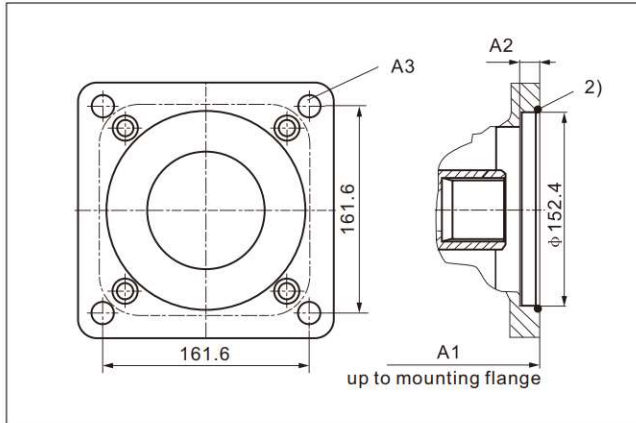

Size	A1		A2			A3	
	K86	K17	K81	K82	K83		
75	290	-	290	-	-	13	M20,28 deep
95/115	317	-	317	317	-	30	M20,25 deep
130/145	340	350	340	340	340	30	M20,25 deep
130/145*	374	384	374	374	374	30	M20,25 deep
190*	424	424	424	424	424	13	M20,22 deep
260*	459	459	459	459	459	13	M20,22 deep

*) Version with charge pump

Flange SAE J744-165-4(E)
Coupler for splined shaft acc.to ANSI B92,1a-1976
Coupler for splined shaft acc.to DIN 5480

1 3/4in 13T 8/16DP¹⁾ (SAE J744-32-4(C)) K72
W50×2×30×24×9g K84
W60×2×30×28×9g K67

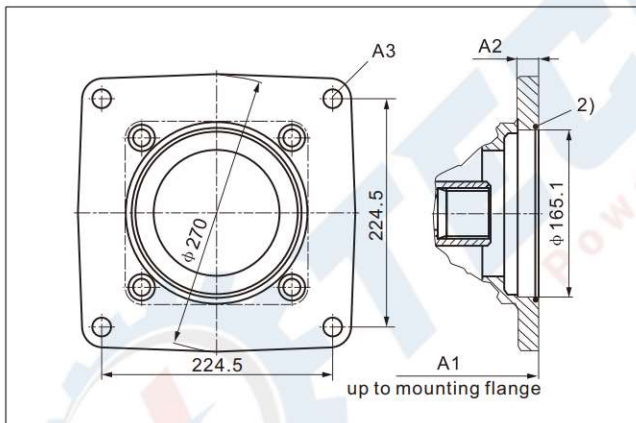

Size	A1		A2		A3	
	K72	K84	K67			
190*	409	409	-	19		M20;20 deep
260*	459	442.5	442.5	19		M20;20 deep

*) Version with charge pump

Note:
The mounting flange may be turned through 90° .Standard position as illustrated.Please state in clear text if required.
1) 30° pressure angle,flat root,side fit,tolerance class 5.
2)O-ring included in the delivery contrnts.

■ Installation Notes

● General

During commissioning and operation, the axial piston unit must be filled with hydraulic fluid and air bled. This is also to be observed following a relatively long standstill as the system may empty via the hydraulic lines.

The case drain in the case interior must be directed to the tank via the highest tank port (T1, T2). The minimum suction pressure at port S must not fall below 0.08 Mpa absolute (without charge pump) or 0.06MPa (with charge pump).

In all operational conditions, the suction line and case drain line must flow into the tank below the minimum fluid level.

● Below-tank installation(standard)

Pump below the minimum fluid level of the tank.

- Any installation position
- Mounting position "shaft up"

It must be ensured that the pump casing is completely filled with oil during commissioning. If air bubbles appear at the bearing, it will damage the axial plunger/bengbu.

● Above-tank installation

Pump above the minimum fluid level of the tank.
Observe the maximum permissible suction height
 $H_{s\ max}=800\ mm$.

The version A11VLO (with charge pump) is not designed for installation above the tank.

Recommendation for installation shaft up: A check valve in the case drain line (opening pressure 0.05MPa) can prevent the case interior from draining.

For control options with pressure control, displacement limiters, HD and EP control, the minimum displacement setting must be $V_g \geq 5\% V_{g\ max}$.

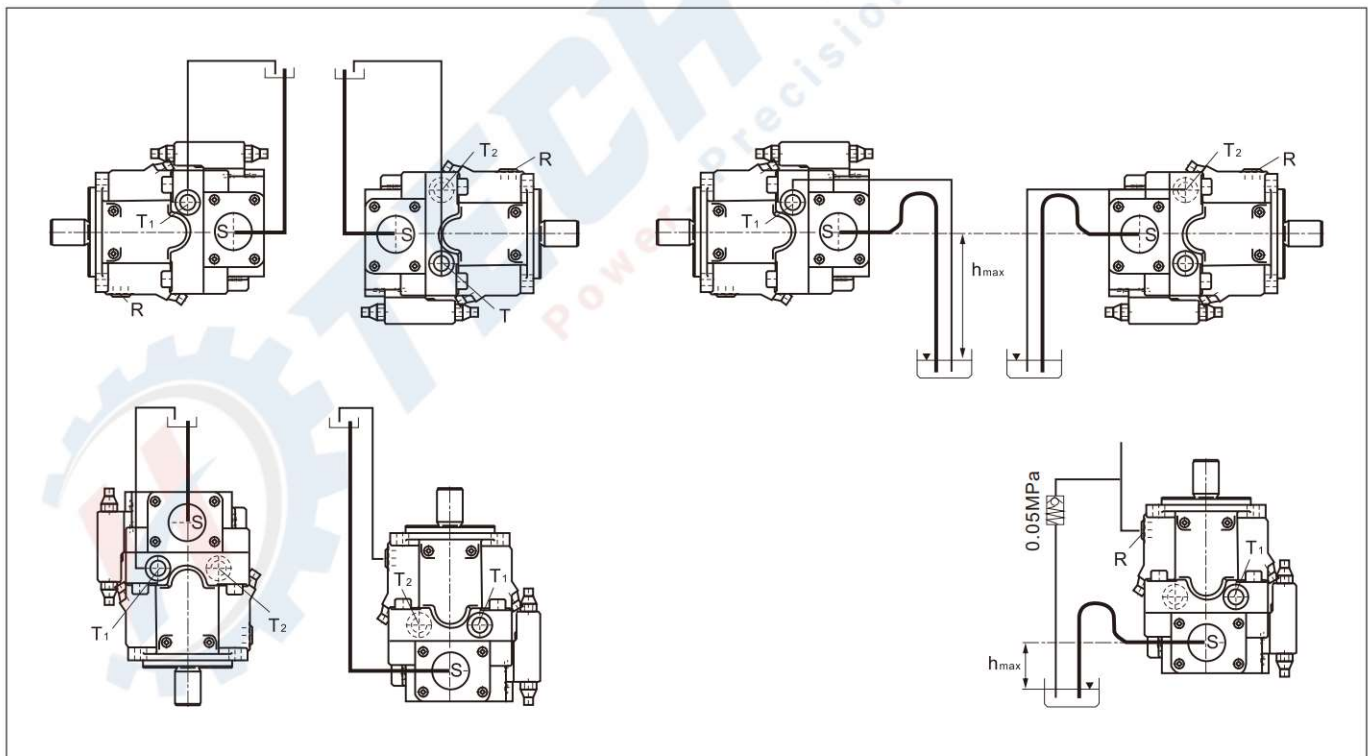

FOR MORE INFORMATION PLEASE CONTACT US

SALES@TECHYDRO.COM.CN



TECHYDRO

- ☎ +86-15869517019
 - ✉ SALES@techhydro.com.cn
 - 🌐 WWW.TECHYDRO.COM.CN
 - 📞 whatsapp/Wechat: +86-15869517019
- TEL: +86(0574) -87021030