

## A4VG Series Axial piston variable pump

### ■ Product show and brief introduction

---

#### Colsed circuits

Series 32

Sizes 56...71

Nominal pressure 40MPa

Maxmum pressure 45MPa



### ■ Features

---

- Integrated auxiliary pump of boost and pilot oil supply
- Flow direction changes when the swashplate is moved through the neutral position
- High-pressure relief valves with integrated boost function
- With adjustable pressure cut-off as standard
- Boost-pressure relief valve
- Through drive for mounting of further pumps up to same size
- Large variety of controls
- Swashplate design

## Model Code

A4V	G	56	EP2	D	M	/32	R	-N	S	C	02	F	02	5	S	P
Axial piston unit	Operating mode	Size	Control unit	Pressure cut-off	Mechanical stroke limiter	series	Direction of rotation	Seals	Drive shaft	Mounting flange	Working port	Boost pump	Through drive	High-pressure relief valve	Filtration	Connector for solenoids
A4V: swash-plate design, variable	G: pump; closed circuit	56	See below	No code: without pressure cut-off D: with pressure cut-off	No code: without mechanical stroke limiter M: mechanical stroke limiter, externally adjustable	32	(Viewed on drive shaft) R: clockwise L: counter-clockwise	NBR (nitrile rubber), shaft seal made of FKM (fluorocarbon rubber)	See below	C: SAE J744 2-hole F: SAE J744 2+4-hole (only 71)	SAE working port A and B, top and bottom, suction port S bottom	See below	See below	See below	See below	DEUTSCH connector molded, 2-pin
		63														
		71														

## Control Unit

Size			56	63	71	
Proportional control hydraulic	pilot-pressure related	without inlet filtration	✓	✓	✓	HD1
		with inlet filtration	✓	✓	✓	HD3
	mechanical servo		✓	✓	✓	HW
Proportional control electric	with proportional solenoid without inlet filtration	U=12V	✓	✓	✓	EP1
		U=24V	✓	✓	✓	EP2
	with proportional solenoid with inlet filtration	U=12V	✓	✓	✓	EP3
		U=24V	✓	✓	✓	EP4
Two-point control, electric	with switching solenoid	U=24V	✓	✓	✓	EZ1
		U=24V	✓	✓	✓	EZ2

## Drive Shafts

Size			56	63	71	
Splined shaft DIN5480	for single pump		✓	✓	✓	Z
	for combination pump - 1st pump		✓	✓	✓	A
Splined shaft ANSI B92.1a	for single pump		✓	✓	✓	S
	for combination pump - 1st pump		✓	✓	✓	T

## Boost Pump

Size			56	63	71	
Without integrated boost pump	without through drive		✓	✓	✓	N
	with through drive		✓	✓	✓	K
Integrated boost pump	with and without through drive		✓	✓	✓	F

## Through Drive

Flange SAE J744	Hub for splined shaft			56	63	71	
Without through drive, only for version N and F				✓	✓	✓	00
82-2(A)	5/8"	9T	16/32DP	✓	✓	✓	01
101-2(B)	7/8"	13T	16/32DP	✓	✓	✓	02
	1"	15T	16/32DP	✓	✓	✓	04
127-2(C)	1 1/4"	14T	12/24DP	✓	✓	✓	07

## High-pressure relief valve

	Setting range		56	63	71	
High-pressure relief valve, pilot operated	10...42MPa	with bypass	✓	✓	✓	1
High-pressure relief valve direct operated, fixed setting	25...42MPa	without bypass	✓	✓	✓	3
		with bypass	✓	✓	✓	5
	10...25MPa	without bypass	✓	✓	✓	4
		with bypass	✓	✓	✓	6

## Filtration boost circuit/external boost pressure supply

		56	63	71	
Filtration in the boost pump suction line		✓	✓	✓	S
Filtration in the boost pump pressure line	Ports for external boost circuit filtration	✓	✓	✓	D
	Attachment filter with cold start valve and visual contamination indicator	✓	✓	✓	P
External boost pressure supply (version without integrated boost pump -N00, K...)		✓	✓	✓	E

## Technical Data

### Hydraulic fluid

The A4VG variable displacement pump is suitable for use with mineral oil

### Viscosity range

We recommend that a viscosity (at operating temperature) for optimum efficiency and service life purposes of

$$V_{opt} = \text{optimum viscosity } 16 \dots 36 \text{ mm}^2/\text{s}$$

Be chosen, taken the tank temperature (closed circuit) into account.

### Limits of viscosity range

The following values apply in extreme cases:

$$V_{min} = 5 \text{ mm}^2/\text{s} \\ \text{short term (} t < 3 \text{ min) at max. permitted temperature} \\ t_{max} = 115^\circ\text{C}$$

$$V_{max} = 1600 \text{ mm}^2/\text{s} \\ \text{short term (} t < 3 \text{ min) with cold start (} P < 3 \text{ MPa,} \\ n \leq 1000 \text{ rpm } t_{min} = -40^\circ\text{C)}$$

Note that the maximum hydraulic fluid temperature must not be exceeded locally either (e.g. bearing area). The temperature in the bearing area is depending on pressure and speed up to 12K higher than the average case drain temperature.

### Selection diagram

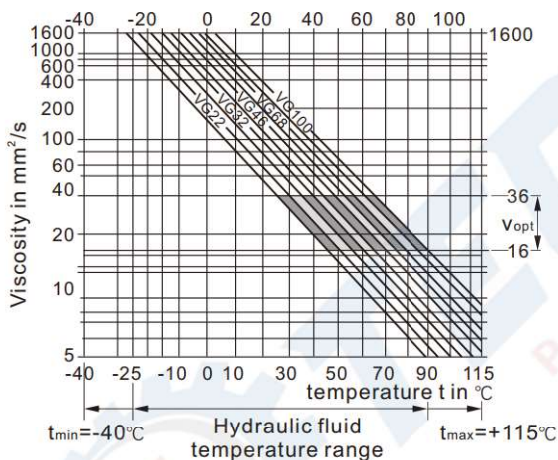

### Details regarding the choice of hydraulic fluid

The correct selection of hydraulic fluid requires knowledge of the operating temperature in relation to the ambient temperature, in an open circuit the tank temperature.

The hydraulic fluid should be selected so that within the operating temperature range, the operating viscosity lies within the optimum range ( $V_{opt}$ ) (see shaded section of the selection diagram). We recommend that the highest possible viscosity range should be chosen in each case.

Example: At an ambient temperature of  $X^\circ\text{C}$  an operating temperature of  $60^\circ\text{C}$  is set in the circuit. In the optimum operating viscosity range ( $V_{opt}$ ; shaded area) this corresponds to the viscosity classes VG 46 or VG 68; to be selected: VG 68.

Please note: The leakage fluid temperature, which is affected by pressure and rotational speed, is always higher than the tank temperature. At no point in the system may the temperature be higher than  $115^\circ\text{C}$ .

### Filtration

Finer filtration improves the cleanliness level of the hydraulic fluid, which increases the service life of the axial piston unit.

A cleanliness level of at least 20/18/15 is to be maintained according to ISO 4406.

At a hydraulic fluid viscosity of less than  $10 \text{ mm}^2/\text{s}$  (e.g. due to high temperatures during short-term operation), a cleanliness level of at least 19/17/14 according to ISO 4406 is required.

### Operational pressure range

Enter:

Variable pump (with external oil supply E)

Charge pressure (at  $n=2000 \text{ rpm}$ )  $P_{sp}$  \_\_\_\_\_ = 2 MPa

Charge pump

Suction pressure  $P_{s \text{ min}}$  ( $V \leq 30 \text{ mm}^2/\text{s}$ ) \_\_\_\_\_  $\geq 0.08 \text{ MPa}$

Output:

Variable pump

Pressure at port A or B

Nominal pressure  $P_N$  \_\_\_\_\_ 40 MPa

Peak pressure  $P_{max}$  \_\_\_\_\_ 45 MPa

Total pressure (pressure A + pressure B)  $P_{max}$  \_\_\_\_\_ 70 MPa

Charge pump

Peak pressure  $P_{sp \text{ max}}$  \_\_\_\_\_ 4 MPa

### Shaft seal

#### Permissible pressure loading

The service life of the shaft seal is influenced by the rotational speed of the axial piston unit and the leakage pressure in the housing (case pressure). Momentary ( $t < 0.1 \text{ s}$ ) pressure peaks of up to 1 MPa are allowed. Case pressure of a continuous 0.2 MPa maximum are permitted to be able to utilize the entire speed range. Higher case pressure are permissible at lower rotational speeds.

The service life of the shaft seal decreases with increasing frequency of pressure peaks and increasing mean differential pressure. The case pressure must be equal to or higher than the ambient pressure.

### Temperature range

The FKM shaft seal ring may be used for leakage temperature from  $-25^\circ\text{C}$  to  $+115^\circ\text{C}$ . For application cases below  $-25^\circ\text{C}$ , an NBR shaft seal is required (permissible temperature range:  $-40^\circ\text{C}$  to  $+90^\circ\text{C}$ ).

## Technical Data

Size			56	63	71	
Geometric displacement, per revolution						
variable pump	$V_{g \max}$	mL/r	56	63	71	
boost pump (at P=2MPa)	$V_{g \text{ sp}}$	mL/r	15.8	15.8	19.6	
Rotational speed						
maximum at $V_{g \max}$	$n_{\max \text{ continuous}}$	rpm	3600	3600	3300	
limited maximum <sup>1)</sup>	$n_{\max \text{ limited}}$	rpm	3900	3900	3600	
intermittent maximum <sup>2)</sup>	$n_{\max \text{ interm}}$	rpm	4500	4500	4100	
minimum	$n_{\min}$	rpm	500	500	500	
Flow						
at $n_{\text{nom}}$ and $V_{g \max}$	$q_{v \max}$	L/min	202	227	234	
Power <sup>3)</sup>						
at $n_{\text{nom}}$ and $V_{g \max}$	$\Delta P=40\text{MPa}$	$P_{\max}$	kW	134	151	156
Torque <sup>3)</sup>						
with at $V_{g \max}$	$\Delta P=40\text{MPa}$	$T_{\max}$	Nm	356	401	451
	$\Delta P=10\text{MPa}$	T	Nm	89	100	113
Moment of inertia of the rotary group	J	kgm	0.0066	0.0066	0.0097	
Maximum angular acceleration <sup>4)</sup>			rad/s <sup>2</sup>	24000	24000	21000
Maximum speed change <sup>4)</sup>			rpm	72	72	69
Case volume	V	L	1.5	1.5	1.3	
Weight (without through drive) approx.	M	kg	38	38	50	

1) Valid at half corner power (e.g. at  $V_{g \max}$  and  $P_n/2$ )

2) Valid at  $\Delta P=7\text{MPa}$  to  $15\text{MPa}$  or  $\Delta P < 30\text{MPa}$  and  $t < 0.1\text{s}$

3) without boost pump

4) the limit value is only valid for a single pump.

### Determining the nominal value

$$\text{Flow } q_v = \frac{V_g \times n \times \eta_v}{1000} \quad (\text{L/min})$$

$$\text{Torque } T = \frac{V_g \times \Delta P}{20 \times \pi \times \eta_{mh}} \quad (\text{Nm})$$

$$\text{Power } P = \frac{2\pi \times T \times n}{60000} = \frac{q_v \times \Delta P}{600 \times \eta_t} \quad (\text{kW})$$

$V_g$  = Displacement per revolution in mL/r

$\Delta P$  = Differential pressure in bar

$n$  = Speed in rpm

$\eta_v$  = Volumetric efficiency

$\eta_{mh}$  = Mechanical-hydraulic efficiency

$\eta_t$  = Overall efficiency ( $\eta_t = \eta_v \cdot \eta_{mh}$ )

## High-pressure Relief Valves

### Setting ranges

High-pressure relief valve, direct operated (size 56,63)	Differential pressure setting $\Delta P_{HD}$
Setting range valve 3,5 $\Delta P_{HD} = 27-42\text{MPa}$	42 MPa
	40 MPa
	36 MPa
	34 MPa
	32 MPa
	30 MPa
	27 MPa
Setting range valve 4,6 $\Delta P_{HD} = 10-25\text{MPa}$	25 MPa
	23 MPa
	20 MPa
	15 MPa
	10 MPa

High-pressure relief valve, pilot operated (size 71)	Differential pressure setting $\Delta P_{HD}$
Setting range valve 4,6 $\Delta P_{HD} = 10-42\text{MPa}$	42 MPa
	40 MPa
	36 MPa
	34 MPa
	32 MPa
	30 MPa
	27 MPa
	25 MPa
	23 MPa
	20 MPa
	15 MPa
10 MPa	

### Setting diagram

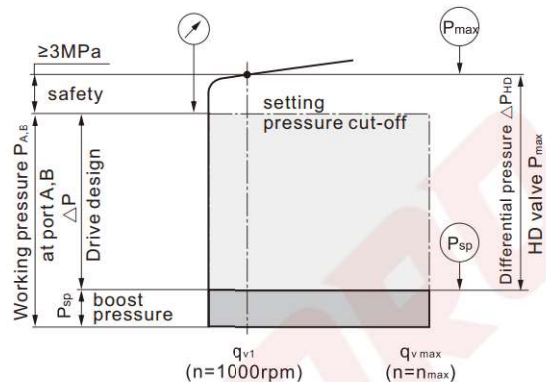

Note: the valve settings are made at  $n=1000$  rpm and at  $V_{g,max}(q_{v1})$ ,

Example: charge pressure 3 MPa, working pressure 40 MPa  
 working pressure  $P_{A,B}$  - Boost pressure  $P_{sp}$  + Safety = Differential pressure  $\Delta P_{HD}$   
 40 MPa - 3 MPa + 3 MPa = 40 MPa

### Bypass function

A connection between the two high-pressure passages A and B can be established using the bypass function (e.g. for machine towing).

## Pressure cut-off, D

The pressure cut-off is a pressure control which, after reaching the set pressure, adjusts the displacement of the pump back to  $V_{gmin}$ .

This valve prevents the operation of the high-pressure relief valves when accelerating or decelerating.

The high-pressure relief valves protect against the pressure peaks which occur during fast swiveling of the swashplate and limit the maximum pressure in the system.

The setting range of the pressure cut-off may be anywhere within the entire working pressure range. However, it must at least be set 3 MPa lower than the setting value of the high-pressure relief valves.

Please state the setting value of the pressure cut-off in plain text when ordering.

## HD-Proportional control,hydraulic,pilot-pressure related

The output flow of the pump is infinitely variable between 0 and 100%,proportional to the difference in pilot pressure applied to the two pilot signal ports (Y1 and Y2).

The pilot signal,coming from an external source, is a pressure signal.Flow is negligible,as the pilot signal acts only on the control spool of the control valve.

This control spool then directs control oil into and out of the stroking cylinder to adjust pump displacement as required. A feedback lever connected to the stroking piston maintains the pump flow for any given pilot signal within the control range.

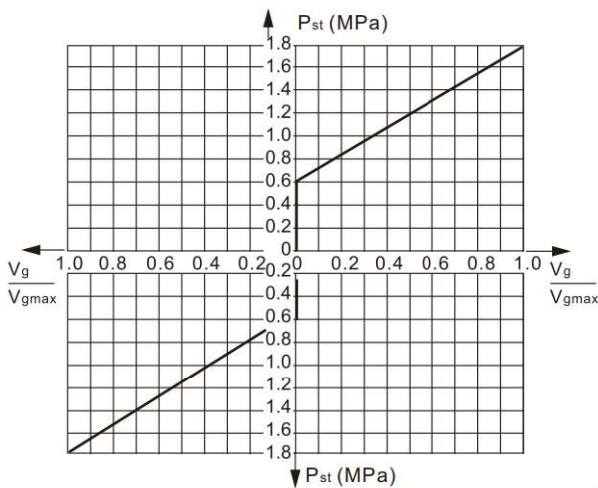

$V_g$  Displacement  
 $V_{gmax}$  Maximum displacement

Pilot pressure  $P_{st}=0.6-1.8\text{MPa}$  for Ports Y1,Y2  
 Start of control 0.6MPa (at  $V_{g0}$ )  
 End of control 1.8MPa (at  $V_{gmax}$ )

Notice:  
 In the neutral position,the HD control module must be unloaded to reservoir via the external pilot control device.

### Correlation of direction of rotation, control and flow direction

		Size	Pilot signal	Control pressure	Flow direction	Working pressure
Direction of rotation	Clockwise	56,63	Y1	X1	A to B	$M_B$
			Y2	X2	B to A	$M_A$
	71	Y1	X1	B to A	$M_A$	
		Y2	X2	A to B	$M_B$	
Counter-clockwise	56,63	56,63	Y1	X1	B to A	$M_A$
			Y2	X2	A to B	$M_B$
	71	71	Y1	X1	A to B	$M_B$
			Y2	X2	B to A	$M_A$

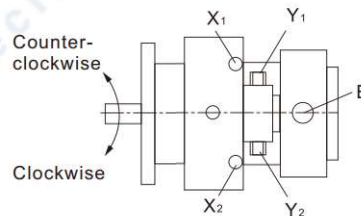
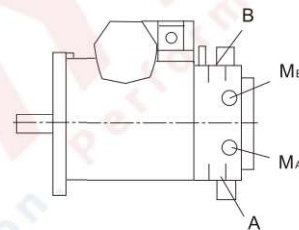

### Circuit diagram HD3

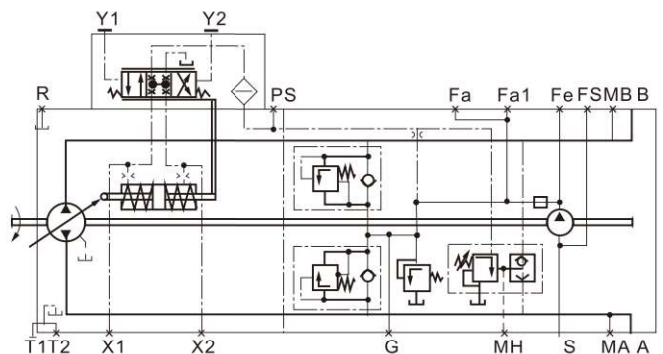

## HW-Proportional control,hydraulic,mechanical servo

The output flow of the pump is infinitely variable between 0 and 100%,proportional to the swivel angle of the control lever.  
A feedback lever connected to the stroking piston maintains the pump flow for any given position of the control lever.

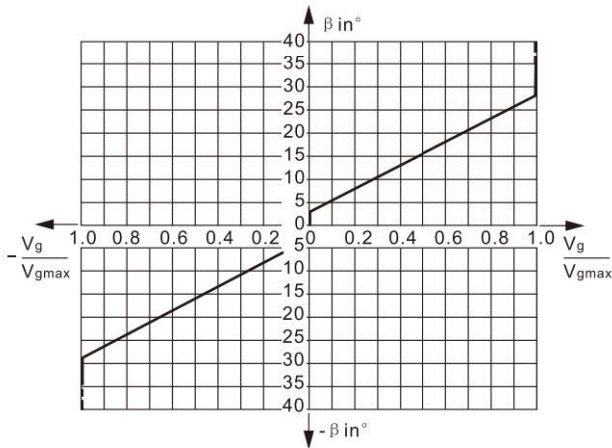

The swing angle of the lever when swinging  $\beta$  :  
Start of control  $\beta = \pm 3^\circ$  (at  $V_{g0}$ )  
End of control  $\beta = \pm 29^\circ$  (at  $V_{gmax}$ )  
Rotational limiter control  $\beta = \pm 40^\circ$

The maximum required torque at control lever is 170 Ncm. To prevent damage to the HW control module, a positive mechanical stop of  $38^\circ \pm 1$  must be provided for the HW control lever on the customer side.

### • Circuit diagram HW

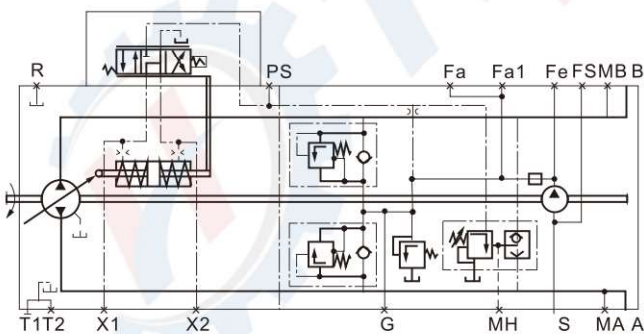

### • Correlation of direction of rotation, control and flow direction

	Size	Lever direction	Control pressure	Flow direction	Working pressure
Direction of rotation Clockwise	56,63	a	X <sub>2</sub>	B to A	M <sub>A</sub>
		b	X <sub>1</sub>	A to B	M <sub>B</sub>
	71	a	X <sub>2</sub>	A to B	M <sub>B</sub>
		b	X <sub>1</sub>	B to A	M <sub>A</sub>
Direction of rotation Counter-clockwise	56,63	a	X <sub>2</sub>	A to B	M <sub>B</sub>
		b	X <sub>1</sub>	B to A	M <sub>A</sub>
	71	a	X <sub>2</sub>	B to A	M <sub>A</sub>
		b	X <sub>1</sub>	A to B	M <sub>B</sub>

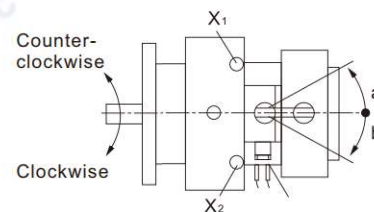
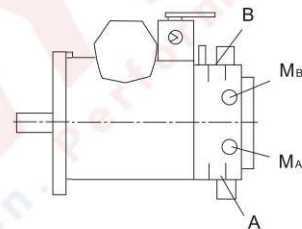

#### Notice:

Spring-centering enables the pump, depending on pressure and rotational speed, to move automatically to the neutral position ( $V_g = 0$ ) as soon as there is no longer any torque on the control lever of the HW control module.

As standard delivery, the control lever can be changed toward the through drive (see dimensions).

If necessary, the position of the lever can be changed. The procedure is defined in the instruction manual.

The position of the control lever can deviate from the installation drawing.

## ■ EP-Proportional control,electric

The output flow of the pump is infinitely variable between 0 and 100%,proportional to the electric current supplied to solenoid a or b.

The electrical energy is converted into a force acting on the control spool.This control spool then directs control oil into and out of the stroking cylinder to adjust pump displacement as required. A feedback lever connected to the stroking piston maintains the pump flow for any given current within the control range.

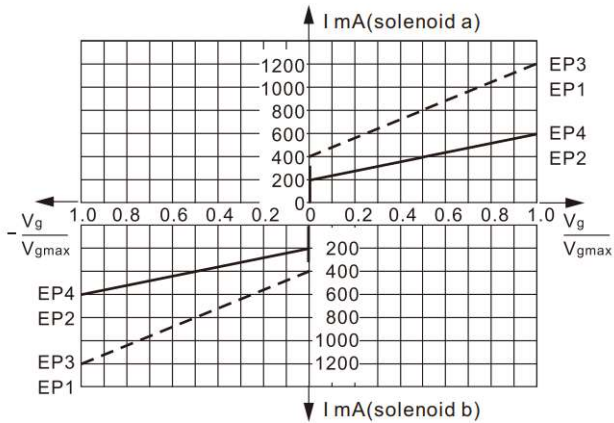

Notice:  
The proportional solenoid do not have manual override.  
Proportional solenoid with manual override and spring return are available on request.

Technical data, proportional solenoid	EP3/1	EP4/2
Voltage	12V DC(±20%)	24V DC(±20%)
Control current		
Start of control at $V_{g0}$	400mA	200mA
End of control at $V_{gmax}$	1200mA	600mA
Current limit	1.54A	0.77A
Nominal resistance(at 20°C)	5.5Ω	22.7Ω
Frequency	100Hz	100Hz
Duty cycle	100%	100%
Type of protection	Ip65	

## ● Correlation of direction of rotation, control and flow direction

		Size	Actuation of proportional solenoid	Control pressure	Flow direction	Working pressure
Direction of rotation	Clockwise	56,63	a	X1	A to B	M <sub>B</sub>
			b	X2	B to A	M <sub>A</sub>
	71	a	X1	B to A	M <sub>A</sub>	
		b	X2	A to B	M <sub>B</sub>	
Counter-clockwise	56,63	56,63	a	X1	B to A	M <sub>A</sub>
			b	X2	A to B	M <sub>B</sub>
	71	71	a	X1	A to B	M <sub>B</sub>
			b	X2	B to A	M <sub>A</sub>

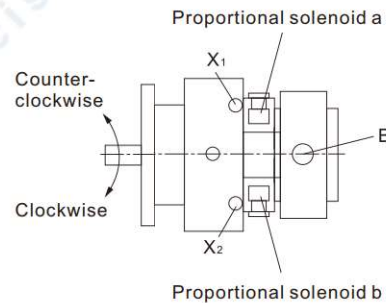
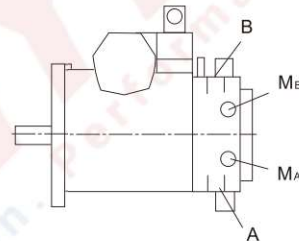

## ● Circuit diagram EP

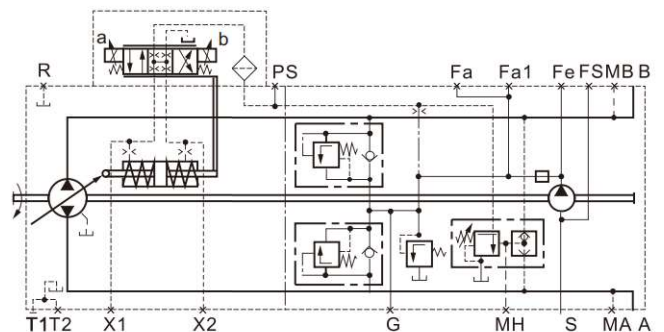

## EZ-Two-point control, electric

By actuating either switching solenoid a or b, internal control pressure is applied directly to the stroking piston and the pump swivels to maximum displacement.

The EZ control enables pump flow to be switched between  $V_g=0$  and  $V_g \text{ max}$ .

Flow direction is determined by which solenoid is energized.

Technical data, switching solenoid	EZ3/1	EZ4/2
Voltage	12V DC( $\pm 20\%$ )	24V DC( $\pm 20\%$ )
Neutral position $V_g=0$	de-energized	de-energized
Position $V_g \text{ max}$	current switched on	current switched on
Nominal resistance(at 20°C)	5.5Ω	22.7Ω
Nominal power	26.2W	26.5W
Minimum required active current	1.32A	0.67A
Duty cycle	100%	100%
Type of protection	Ip65	

Standard: switch electromagnet without manual emergency operation function. Manual emergency operation via spring return is available on request.

### Correlation of direction of rotation, control and flow direction

		Size	Actuation of proportional solenoid	Control pressure	Flow direction	Working pressure
Direction of rotation	Clockwise	56,63	a	X <sub>2</sub>	B to A	M <sub>A</sub>
			b	X <sub>1</sub>	A to B	M <sub>B</sub>
	71	a	X <sub>2</sub>	A to B	M <sub>B</sub>	
		b	X <sub>1</sub>	B to A	M <sub>A</sub>	
Counter-clockwise	56,63	56,63	a	X <sub>2</sub>	A to B	M <sub>B</sub>
			b	X <sub>1</sub>	B to A	M <sub>A</sub>
	71	71	a	X <sub>2</sub>	B to A	M <sub>A</sub>
			b	X <sub>1</sub>	A to B	M <sub>B</sub>

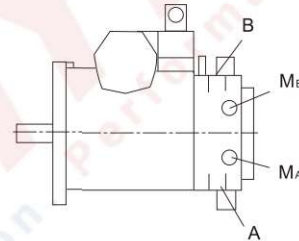

### Circuit diagram EZ

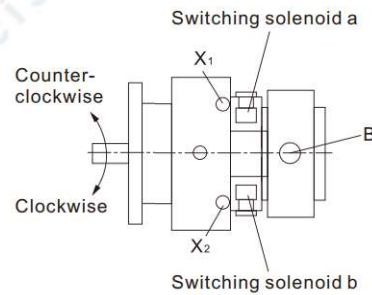
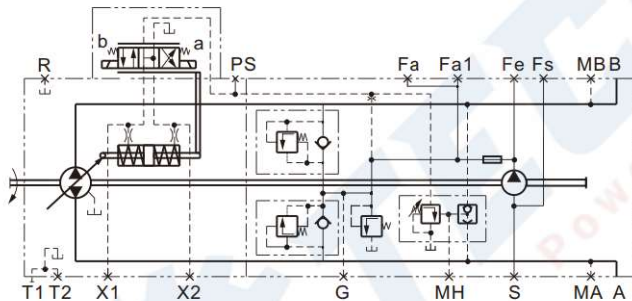

## Installation dimensions Size 56,63

### Without control valve

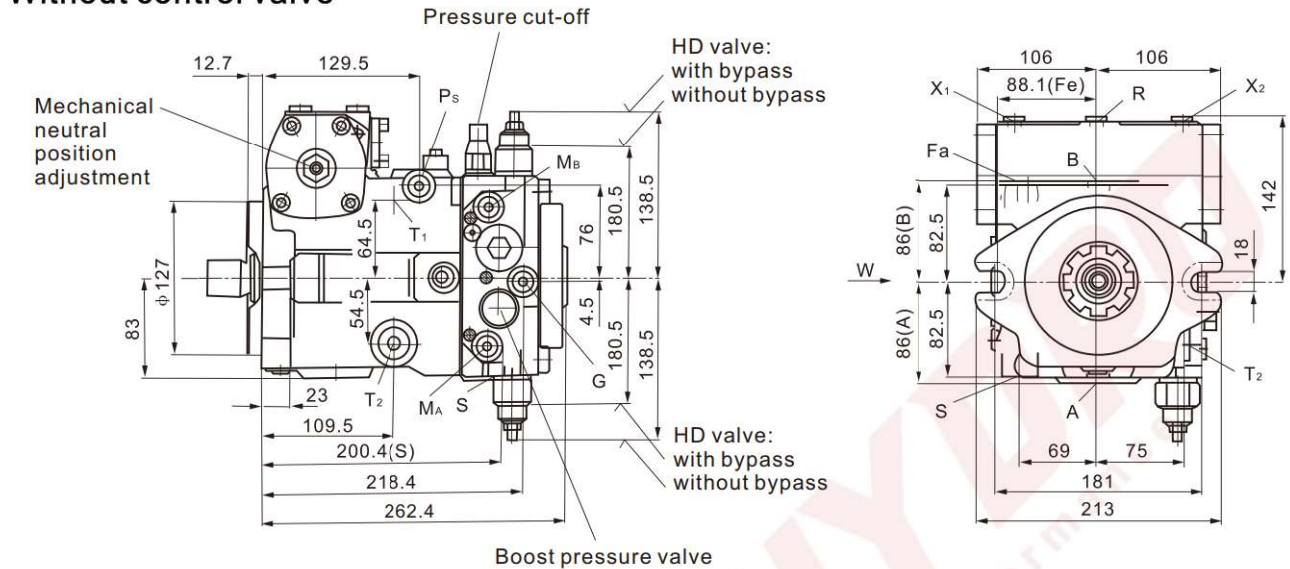

Boost pressure valve

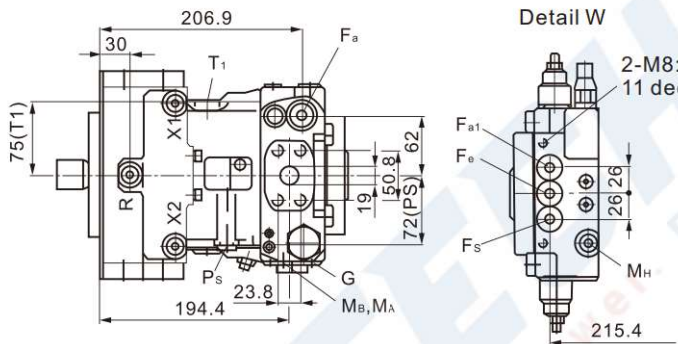

### Ports

A, B	Working port	3/4 in
	Fastening thread	M10; 17 deep
S	Suction port	M33×2; 18 deep
T <sub>1</sub>	Drain port	M22×1.5; 15 deep
T <sub>2</sub>	Drain port	M22×1.5; 15 deep
M <sub>A</sub> , M <sub>B</sub>	Measuring port pressure A, B	M12×1.5; 12 deep
R	Air bleed port	M12×1.5; 15 deep
X <sub>1</sub> , X <sub>2</sub>	Control pressure port (upstream of orifice)	M12×1.5; 12 deep
G	Boost pressure port inlet	M14×1.5; 12 deep
P <sub>s</sub>	Pilot pressure port	M14×1.5; 12 deep
F <sub>a</sub>	Boost pressure port inlet	M18×1.5; 12 deep
F <sub>a1</sub>	Boost pressure port inlet (attachment filter)	M18×1.5; 12 deep
F <sub>e</sub>	Boost pressure port outlet	M18×1.5; 12 deep
F <sub>s</sub>	Line from filler to suction port (cold start)	M18×1.5; 12 deep
M <sub>H</sub>	Measuring port, high pressure	M12×1.5; 12 deep

### Shafts

Z spline shaft DIN5480  
W30×2×30×14×9g

A spline shaft DIN5480  
W35×2×30×16×9g

S spline shaft SAE J744  
1 1/4in 14T 12/24DP<sup>1)</sup>

T spline shaft SAE J744  
1 3/8in 21T 16/32DP<sup>1)</sup>

L spline shaft SAE J744  
with connecting flange

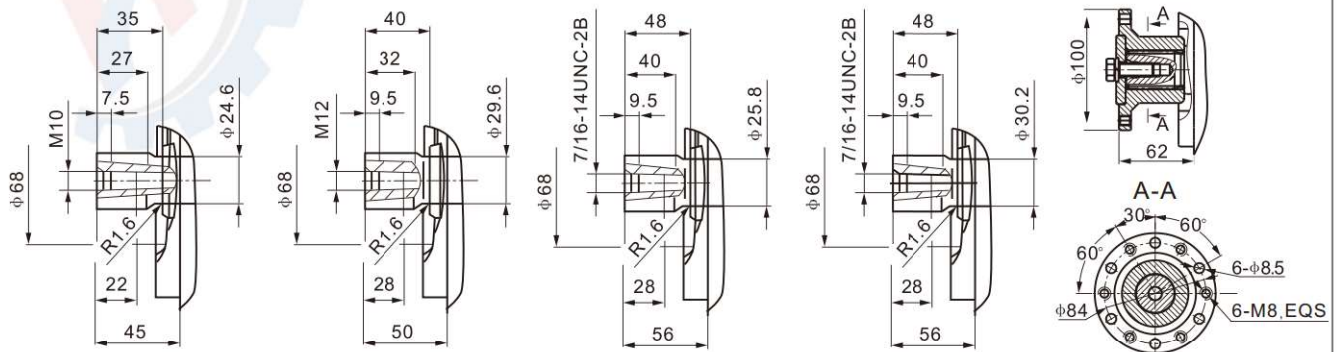

1) Involute spline according to ANSI B92.1a, 30 pressure angle, flat root, side fit, tolerance class 5

■ Installation dimensions Size 56,63

HD-Proportional control,hydraulic,  
pilot-pressure related

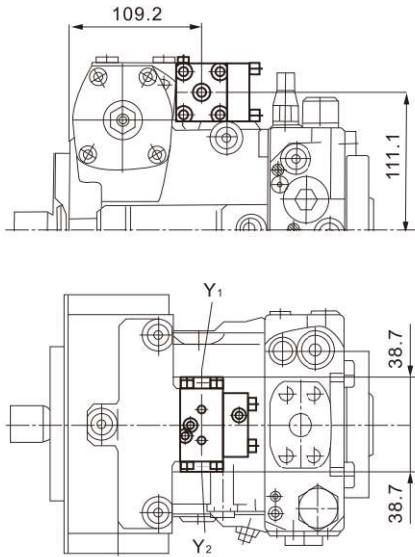

Y<sub>1</sub>,Y<sub>2</sub> Pilot pressure port outlet M14×1.5;12 deep

HW-Proportional control,hydraulic,  
mechanical servo

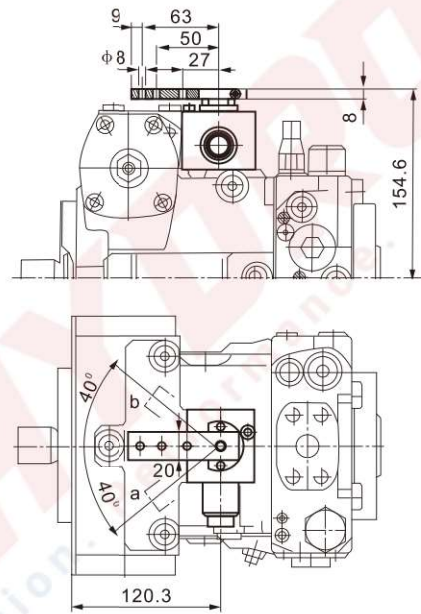

EP-Proportional control,electric

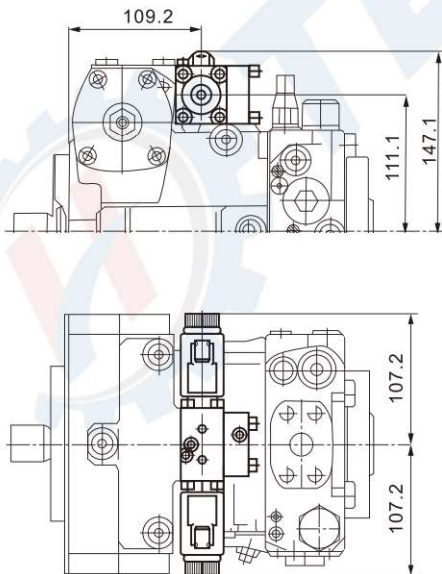

EZ-Two-point control,electric

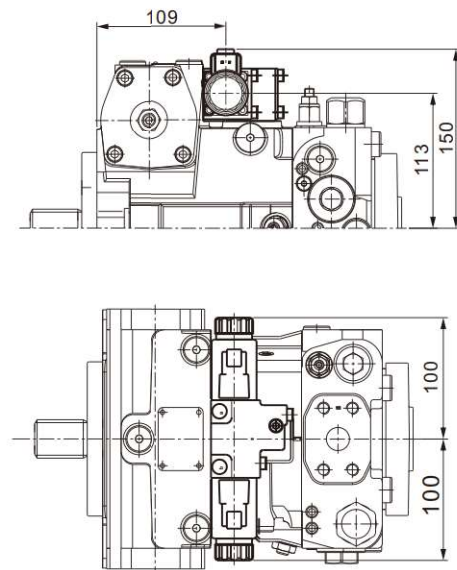

## Installation dimensions Size 71

### Without control valve

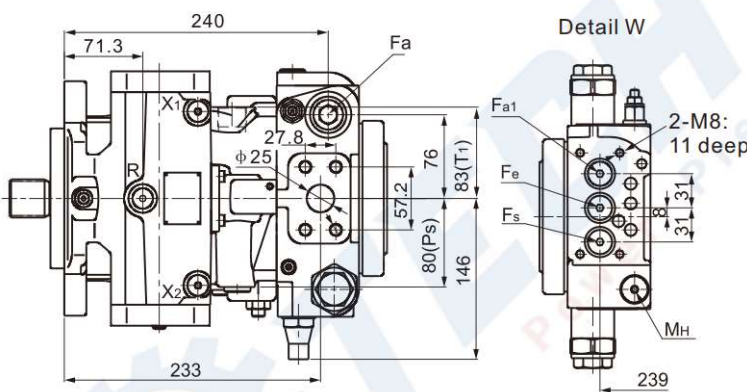
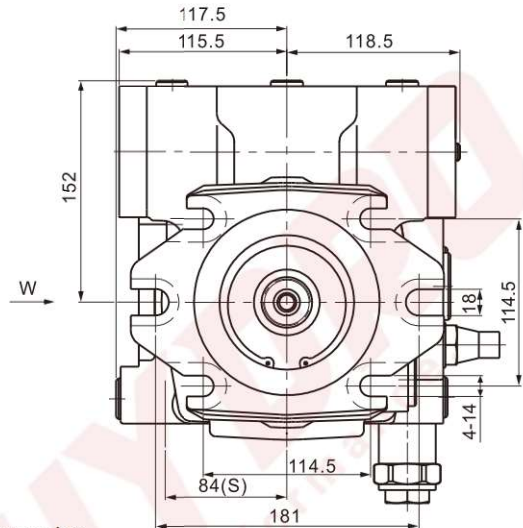
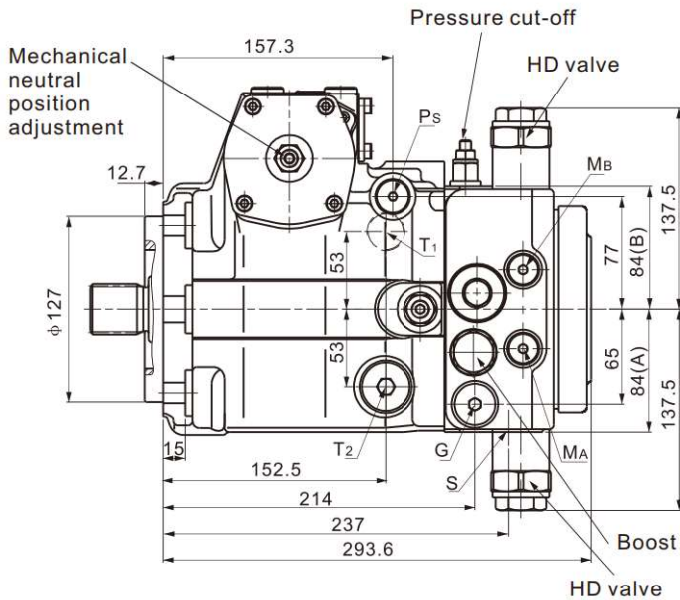

#### Ports

A,B	Working port	1 in
	Fastening thread	M12;17 deep
S	Suction port	M42×2;20 deep
T <sub>1</sub>	Drain port	M26×1.5;16 deep
T <sub>2</sub>	Drain port	M26×1.5;16 deep
M <sub>A</sub> ,M <sub>B</sub>	Measuring port pressure A,B	M12×1.5;12 deep
R	Air bleed port	M12×1.5;12 deep
X <sub>1</sub> ,X <sub>2</sub>	Control pressure port (upstream of orifice)	M12×1.5;12 deep
G	Boost pressure port inlet	M12×1.5;12 deep
P <sub>s</sub>	Pilot pressure port	M14×1.5;12 deep
F <sub>a</sub>	Boost pressure port inlet	M26×1.5;16 deep
F <sub>a1</sub>	Boost pressure port inlet (attachment filter)	M22×1.5;14 deep
F <sub>e</sub>	Boost pressure port outlet	M22×1.5;14 deep
F <sub>s</sub>	Line from filler to suction port (cold start)	M22×1.5;14 deep
M <sub>H</sub>	Measuring port, high pressure	M12×1.5;12 deep

### Shafts

Z spline shaft DIN5480  
W35×2×30×16×9g

A spline shaft DIN5480  
W40×2×30×18×9g

S spline shaft SAE J744  
1 1/4in 14T 12/24DP<sup>1)</sup>

T spline shaft SAE J744  
1 3/8in 21T 16/32DP<sup>1)</sup>

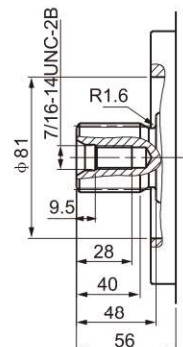
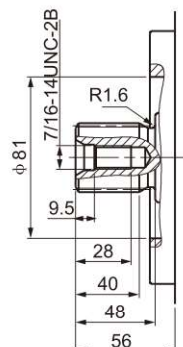
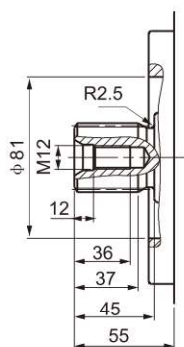
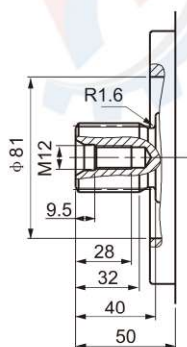

1) Involute spline according to ANSI B92.1a, 30 pressure angle, flat root, side fit, tolerance class 5

**Installation dimensions** Size 71

**HD-Proportional control,hydraulic,  
pilot-pressure related**

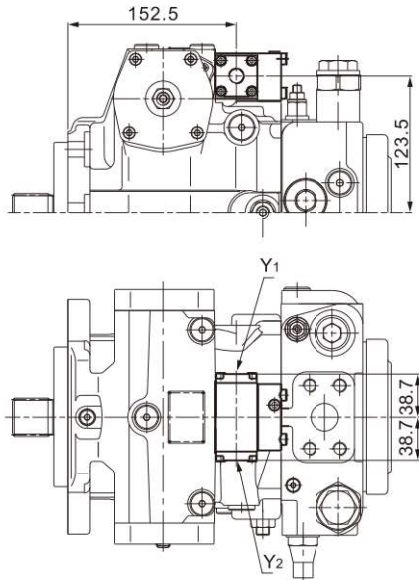

Y<sub>1</sub>, Y<sub>2</sub> Pilot pressure port outlet M14×1.5;12 deep

**HW-Proportional control,hydraulic,  
mechanical servo**

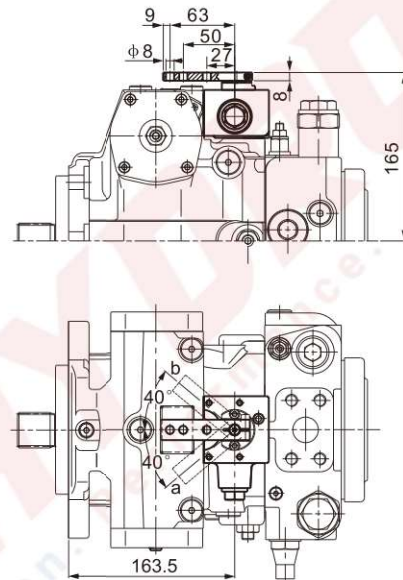

**EP-Proportional control,electric**

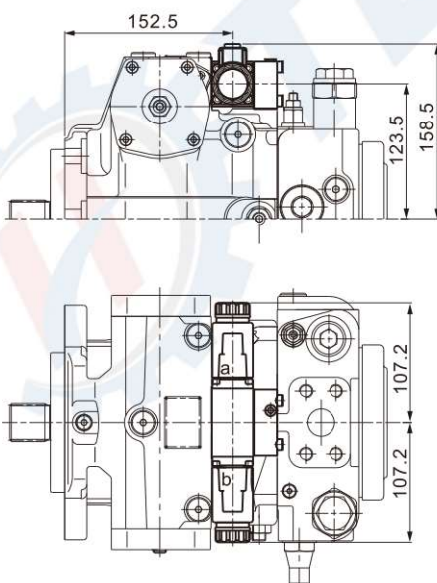

**EZ-Two-point control,electric**

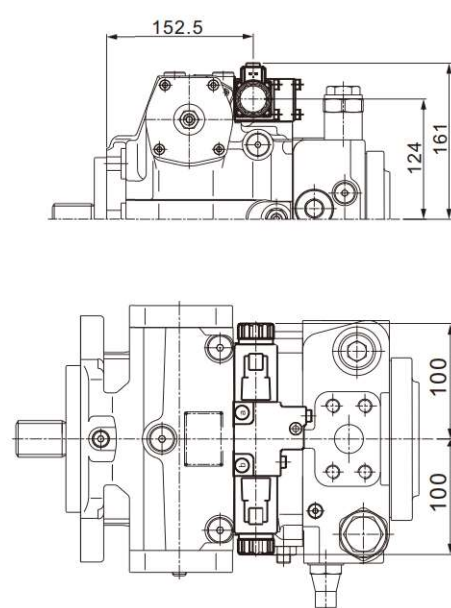

## Installation dimensions, through drive

N00-without boost pump  
F00-with boost pump

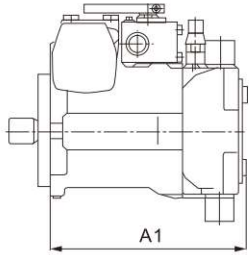

Size	A1	
	N00	F00
56,63	239.4	262.4
71	279.1	293.6

F01/K01  
Flange SAE J744  
Spline shaft sleeve to ANSI B92.1  
5/8in 9T 16/32DP<sup>1)</sup>

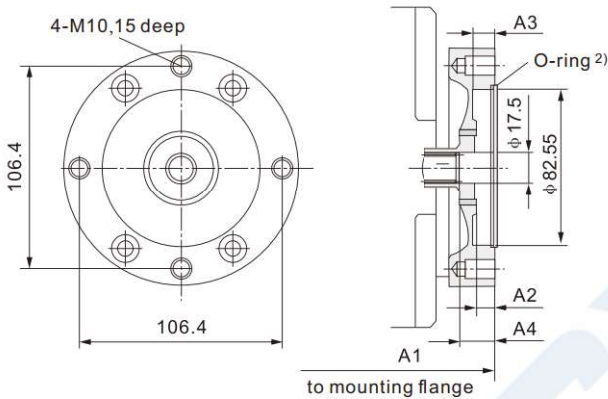

Size	A1(F01)	A1(K01)	A2	A3	A4
56,63	267.4	259.4	10	10	18
71	297.6	297.6	9	10	17

F02/K02  
Flange SAE J744  
Spline shaft sleeve to ANSI B92.1  
7/8in 13T 16/32DP<sup>1)</sup>

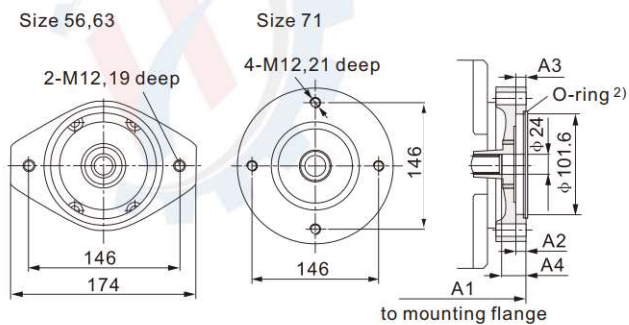

Size	A1	A2	A3	A4
56,63	268.4	12	11	19.5
71	300.6	13	9.8	17

F04/K04  
Flange SAE J744  
Spline shaft sleeve to ANSI B92.1  
1in 15T 16/32DP<sup>1)</sup>

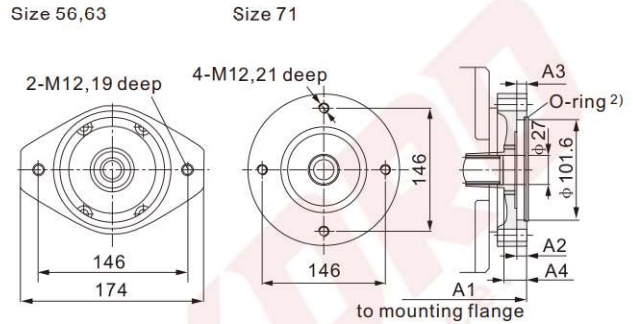

Size	A1	A2	A3	A4
56,63	268.4	13	11	18.5
71	300.6	13	9.8	15.5

F07/K07  
Flange SAE J744  
Spline shaft sleeve to ANSI B92.1  
1 1/4in 14T 12/24DP<sup>1)</sup>

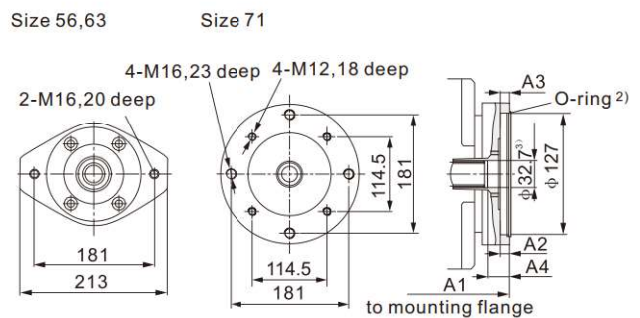

Size	A1	A2	A3	A4
56,63	272.4	15	14	17.5
71	303.6	15	13.5	20

- 1) Involute spline according to ANSI b92, 1a, 30° pressure angle, flat root, side fit, tolerance class 5
- 2) O-ring included in the scope of delivery
- 3) Size 71  $\phi$  33.5

## Mechanical stroke limiter

The mechanical stroke limiter is an auxiliary function allowing the maximum displacement of the pump to be steplessly reduced, regardless of the control module used. By means of two threaded pins, the stroke of the stroking piston and thus the maximum swivel angle of the pump can be limited.

### Circuit diagram

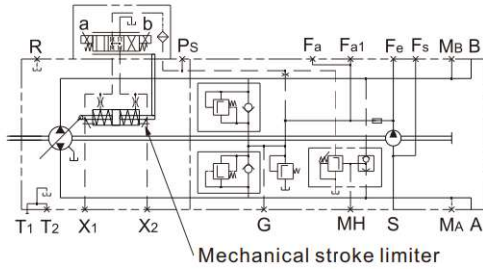

### Dimensions

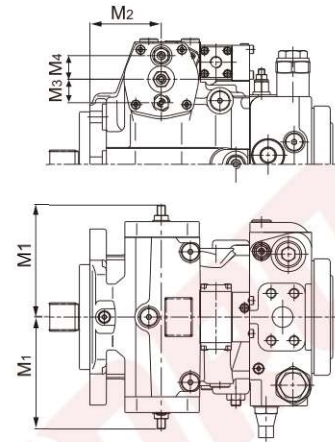

Size	M1	M2	M3	M4
56,63	130.5max	44	25.5	-
71	135.4max	86.3	-	28.5

## Filter type

### Filtration in the boost pump suction line, S

Filter version	Suction filter
Recommendation	With contamination indicator, with cold start valve
Recommended flow resistance at filter element	
At $v=30 \text{ mm}^2/\text{s}, n=n_{\text{max}}$	$\Delta P=0.1 \text{ bar}$
At $v=1000 \text{ mm}^2/\text{s}, n=n_{\text{max}}$	$\Delta P=0.3 \text{ bar}$
Pressure at suction port S	
Continuous $P_{s \text{ min}} (v \leq 30 \text{ mm}^2/\text{s})$	$\geq 0.8 \text{ bar absolute}$
Short-term, at a cold start ( $t < 3 \text{ min}$ )	$\geq 0.5 \text{ bar absolute}$
Maximum pressure $P_{s \text{ max}}$	$\leq 5 \text{ bar absolute}$

### Circuit diagram

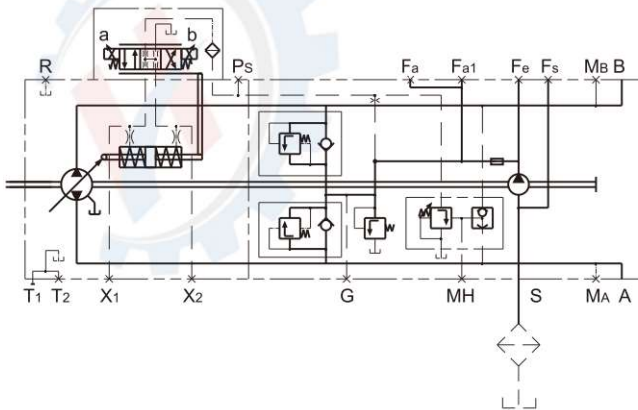

### Attachment filter with cold start valve and visual contamination indicator, P

Filter version	Attachment filter
Recommendation	Version with contamination indicator, (differential pressure)
Filter grade (absolutd)	20 $\mu\text{m}$
Filter material	Glass fiber
Pressure rating	100 bar
Filter arrangement	Mounted on pump
Display type	Green/red window
Differential pressure (switching pressure)	$\Delta P=5 \text{ bar}$

### Circuit diagram

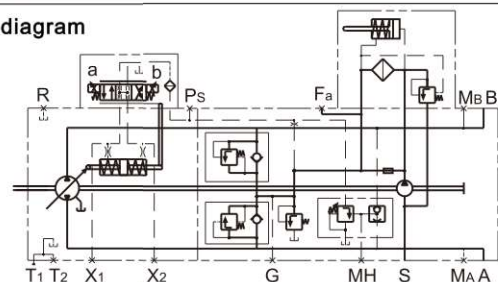

### Dimensions

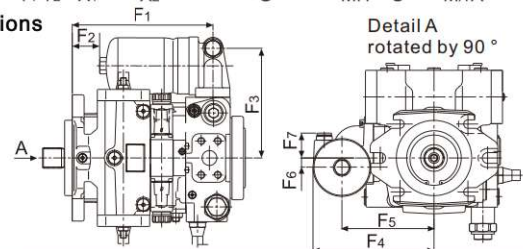

Size	F1	F2	F3	F4	F5	F6	F7
56,63	218.4	64.4	163	178	138	0	78.5
71	239	46.5	185	203.5	155	16	65.5

## Installation instructions

### General

The axial piston unit must be filled with hydraulic fluid and air bled during commissioning and operation. This must also be observed following a longer standstill as the axial piston unit may empty via the hydraulic lines.

Particularly in the installation position "drive shaft upwards", filling and air bleeding must be carried out completely as there is, for example, a danger of dry running.

The leakage in the housing area must be directed to the reservoir via the highest drain port (T1, T2).

For combination pumps, the leakage must be drained off at each single pump.

If a shared drain line is used for several units, make sure that the respective case pressure in each unit is not exceeded. The shared drain line must be dimensioned to ensure that the maximum permissible case pressure of all connected units is not exceeded in any operating condition, particularly at cold start. If this is not possible, separate drain lines must be laid, if necessary.

To achieve favorable noise values, decouple all connecting lines using elastic elements and avoid above-reservoir installation.

Under all operating conditions, the suction line and drain line must flow into the reservoir below the minimum fluid level. The permissible suction height  $h_s$  results from the total pressure loss; it must not, however, be higher than  $h_{s\max}=800$  mm.

The suction pressure at port S must also not fall below the minimum value of 0.8 bar absolute during operation (cold start 0.5 bar absolute).

### Installation position

See the following example. Other installation positions available upon request.

#### Below-reservoir installation (standard)

Below-reservoir installation means that the axial piston unit is installed outside of the reservoir below the minimum fluid level.

#### Above-reservoir installation

Above-reservoir installation means that the axial piston unit is installed above the minimum fluid level of the reservoir. Observe the maximum permissible suction height  $h_{s\max}=800$  mm.

Recommendation for installation position 8 (drive shaft upward): A check valve in the drain line (cracking pressure 0.5 bar) can prevent the housing area from draining.

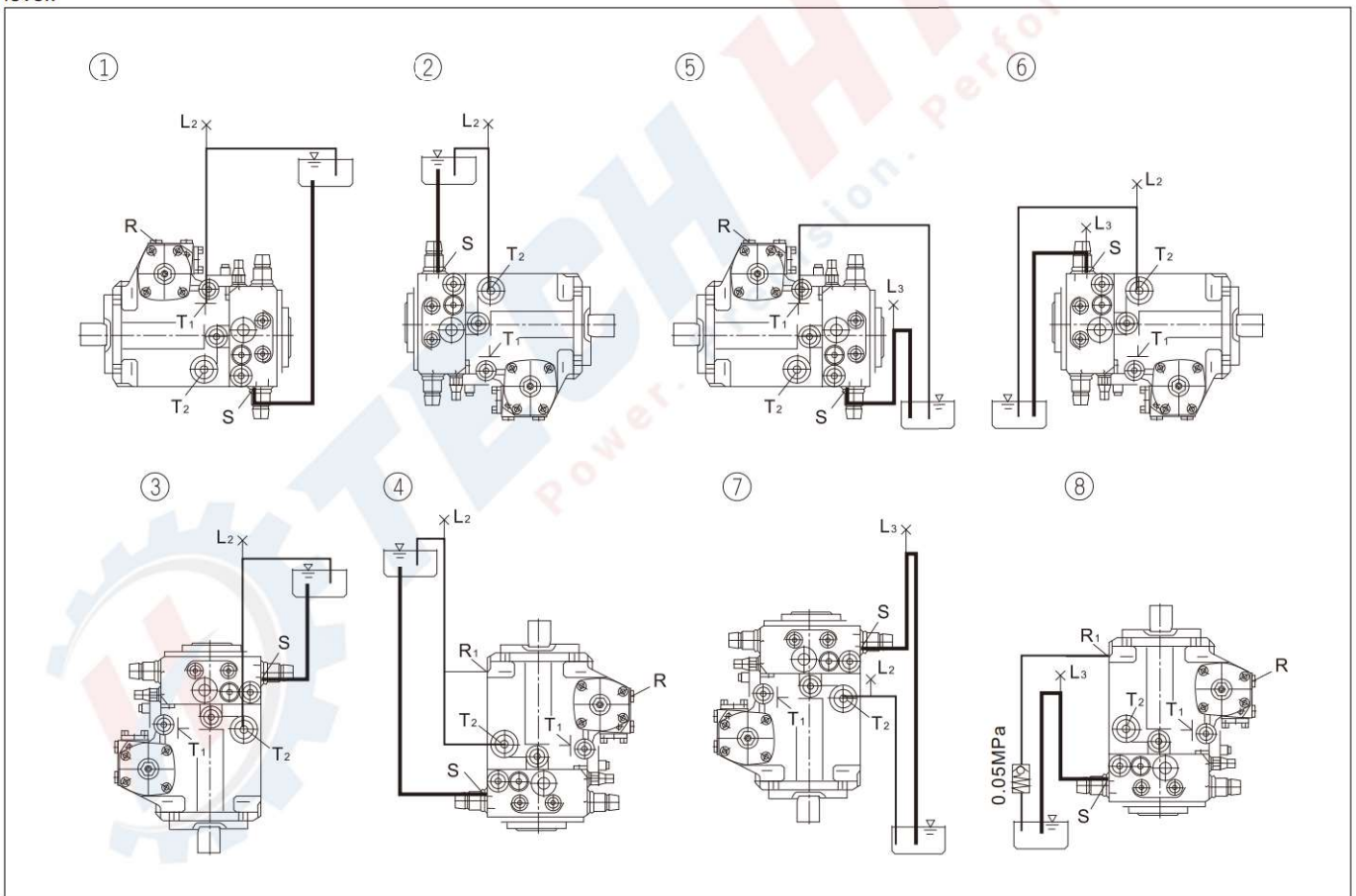

Installation position	Air bleed the housing	Filling
1	R	S+T <sub>1</sub> (L <sub>2</sub> )
2	L <sub>2</sub>	S+T <sub>2</sub> (L <sub>2</sub> )
3	L <sub>2</sub>	S+T <sub>2</sub> (L <sub>2</sub> )
4	R+L <sub>2</sub>	S+T <sub>2</sub> (L <sub>2</sub> )

Installation position	Air bleed the housing	Filling
5	R	T <sub>1</sub> +(L <sub>3</sub> )
6	L <sub>2</sub>	S(L <sub>3</sub> )+T <sub>2</sub> (L <sub>2</sub> )
7	L <sub>2</sub> +L <sub>3</sub>	S(L <sub>3</sub> )+T <sub>2</sub> (L <sub>2</sub> )
8	R+L <sub>3</sub>	S(L <sub>3</sub> )+T <sub>2</sub>

*FOR MORE INFORMATION PLEASE CONTACT US*

*SALES@TECHYDRO.COM.CN*



**TECHYDRO**

☎ +86-15869517019

✉ SALES@techydro.com.cn

🌐 WWW.TECHYDRO.COM.CN

📞 whatsapp/Wechat: +86-15869517019

TEL: +86(0574) -87021030