

A4VTG Series Axial piston variable pump

■ Product show and brief introduction

closed circuits

Series 33
Sizes 90 and 100
Nominal pressure 40MPa
Maximum pressure 45MPa



■ Features

- Variable axial piston pump of swashplate design for hydrostatic drives in closed circuit
- The flow is proportional to the drive speed and displacement.
- The flow increases as the angle of the swashplate is adjusted from zero to its maximum value.
- Flow direction changes smoothly when the swashplate is moved through the neutral position.
- Two pressure-relief valves are provided on the high pressure ports to protect the hydrostatic transmission (pump and motor) from overload.
- The high-pressure relief valves also function as boost valves.
- The integrated boost pump acts as a feed pump and control pressure supply.
- The maximum boost pressure is limited by a built-in boost pressure-relief valve.
- Tapered shaft option for direct drive shaft yoke installation.

Model Code

A4VT	G	90	HW	M	T	/33	R	-N	S	D	10	F	02	5	S
Axial piston unit	Operating mode	Size	Control unit	Mechanical stroke limiter	stroking chamber pressure port	series	Direction of rotation	Seals	Drive shaft	Mounting flange	Working port	Boost pump	Through drive	High-pressure relief valve	Filtration
A4VT: swash-plate design, variable	G: pump; closed circuit	90 100	See below	No code: without mechanical stroke limiter M: with mechanical stroke limiter	No code: without stroking chamber pressure port X ₃ , X ₄ T: stroking chamber pressure port X ₃ , X ₄	33	(Viewed on drive shaft) R: clockwise L: counter-clockwise	NBR (nitrile rubber), shaft seal made of FKM (fluorocarbon rubber)	See below	D: SAE J744 4-hole	SAE working port A and B, same side right, suction port S at top	Integrated boost pump	See below	High-pressure relief valve direct operated, fixed setting, with bypass	Filtration in the boost pump suction line

Control unit

Size		90	100	
Proportional control hydraulic	mechanical servo	✓	✓	HW
Proportional control electric	with proportional solenoid without inlet filtration	U=12V	✓	EP1
		U=24V	✓	EP2

Drive shafts

Size		90	100	
Splined shaft ANSI B92.1a-1976	without connecting flange	✓	✓	S
	with connecting flange	✓	✓	L

Technical Data

size				90	100
Displacement	variable pump	V_{gmax}	mL/r	90	100
	boost pump(at P=20bar)	V_{gsp}	mL/r	28.3	28.3
Speed	maximum at V_{gmax}	n_{nom}	rpm	3050	3050
	minimum	n_{min}	rpm	500	500
Flow	at n_{nom} and V_{gmax}	q_{vmax}	L/min	275	305
Power	at n_{nom} V_{gmax} and $\Delta P=40MPa$	P_{max}	kW	183	204
Torque	at V_{gmax} and $\Delta P=40MPa$	T_{max}	Nm	572	637
		T	Nm	143	159
Moment of inertia rotary group		J	kgm ²	0.0106	0.0106
Weigh(without through drive) approx.		m.	kg	48	48

HW-Proportional control hydraulic,mechanical servo

The output flow of the pump can be steplessly varied in the range between 0 to 100%,proportional to the rotation of the control lever between 0° and $\pm 29^\circ$.

A feedback lever connected to the stroke piston maintains the pump flow for any given position of the control lever between 0° and 29°

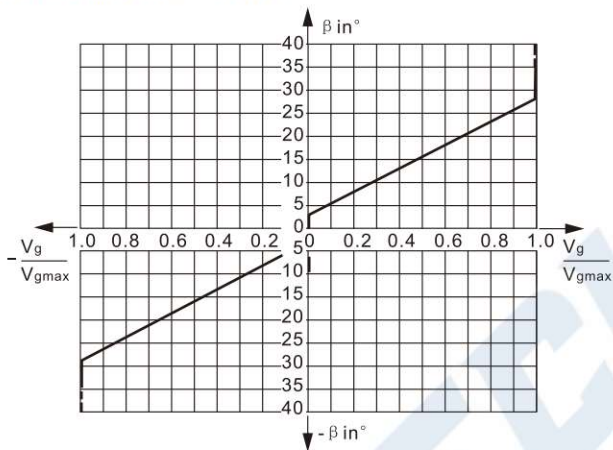

Swivel angle β at the control lever for deflection:

Start of control at $\beta = 3^\circ$

End of control at $\beta = 29^\circ$ (maximum displacement V_{gmax})

Mechanical stopfor: $\beta = \pm 40^\circ$

The maximum required torque at the lever is 170 Ncm.

To prevent damage to the HW control unit,a positive mechanical stop must be provided for the HW control lever.

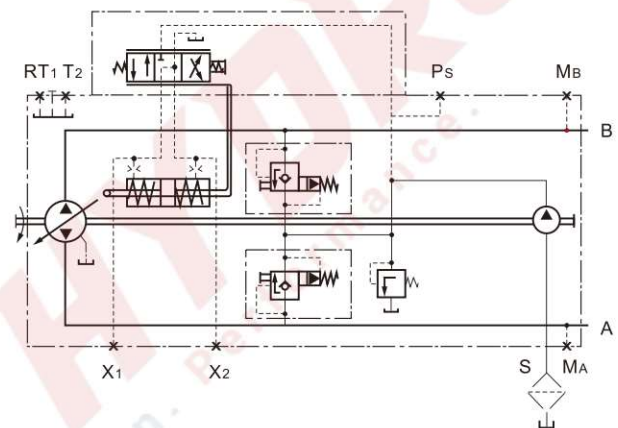

Direction of rotation - Control - Flow direction

Direction of rotation	CW		CCW	
	a	b	a	b
Lever direction	a	b	a	b
Control pressure	X ₂	X ₁	X ₂	X ₁
Flow direction	B to A	A to B	A to B	B to A
Operating pressure	M _A	M _B	M _B	M _A

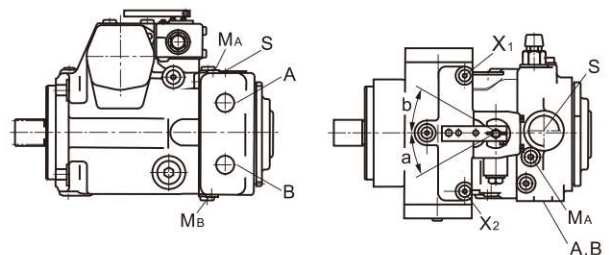

■ EP- Proportional control electric

The output flow of the pump can be steplessly varied in the range between 0 to 100%,proportional to the electrical current supplied to solenoid a or b.

The electrical energy is converted into a force acting on the control piston.This control piston then directs control hydraulic fluid into and out of the stroke cylinder to adjust pump displacement as required.

A feedback lever connected to the stroke piston maintains the pump flow for any given current within the control range.

比例电磁铁

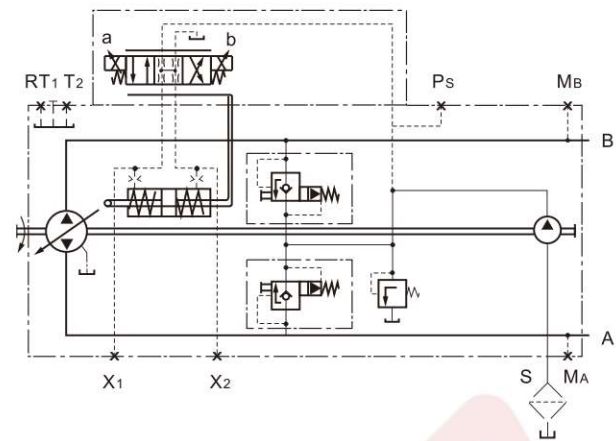

Direction of rotation - Control - Flow direction

Direction of rotation	CW		CCW	
Actuation of solenoid	a	b	a	b
Control pressure	X1	X2	X1	X2
Flow direction	A to AB	B to A	B to A	A to B
Operating pressure	MB	MA	MA	MB

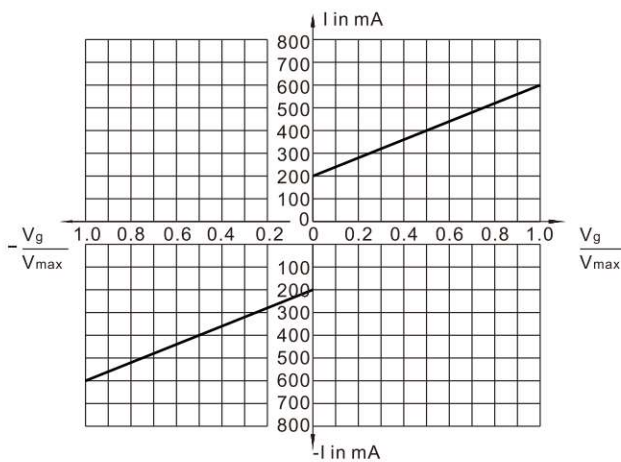

size	Voltage	Control current	
		Start of control at Vg0	End of control at Vg0
EP1	12V	400mA	1200mA
EP2	24V	200mA	600mA

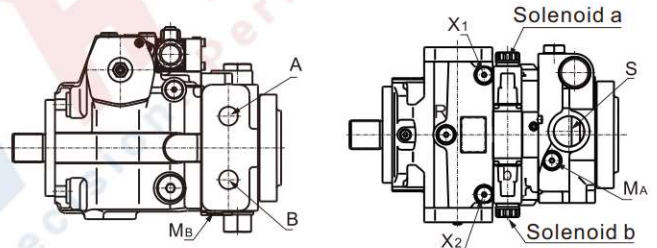

Installation Dimensions

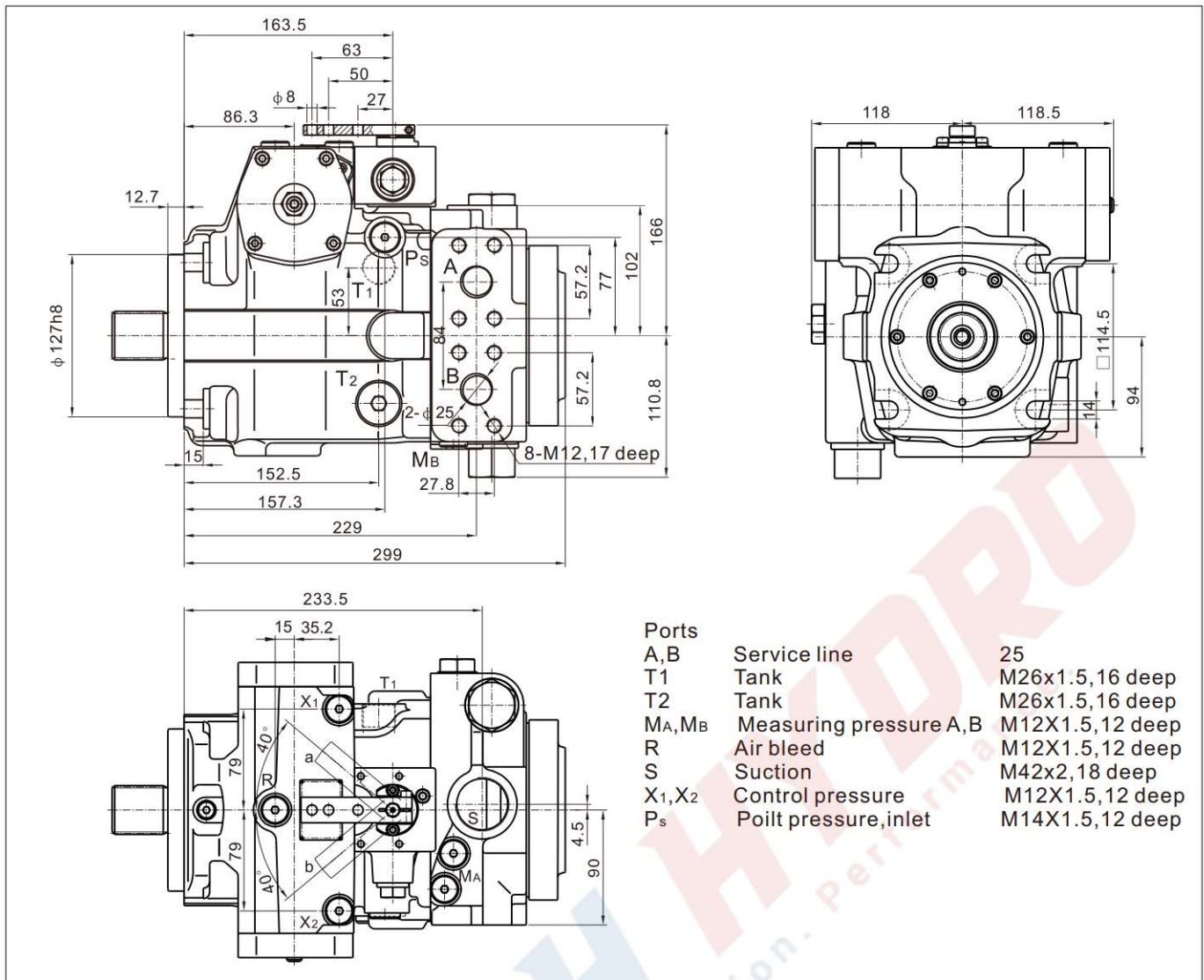

Drive shaft

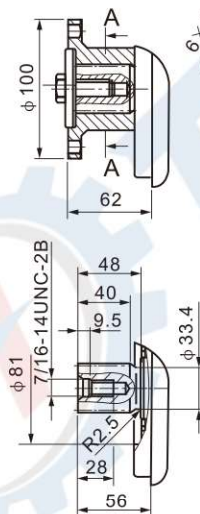

Section A-A

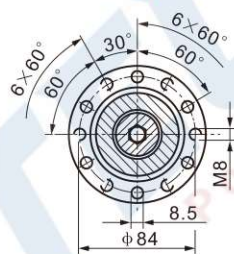

L
spline shaft
SAE 1-1/2"
with conneting flange

S
Spline shaft SAE 1-1/2"
30° angle
23T 16/32DP
Flat tooth heel
Lateral centering of the teeth
Tolerance class 5
ANSI B92.1-1976

EP Electrical control with proportional solenoid

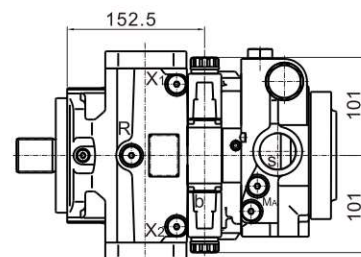
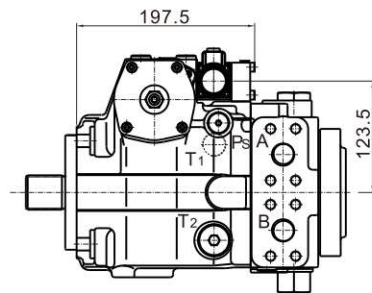

■ Through drive dimensions

Through drive SAE A(F01)

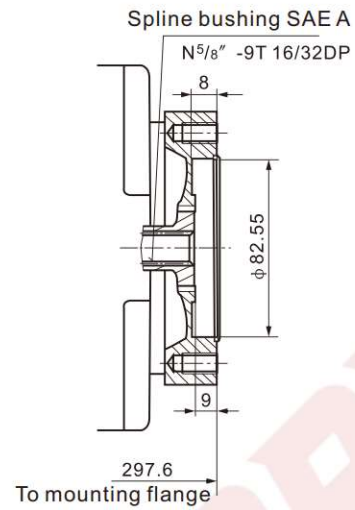
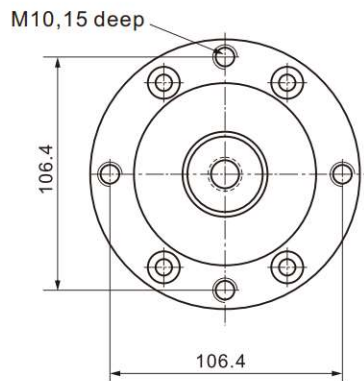

Through drive SAE B(F02)

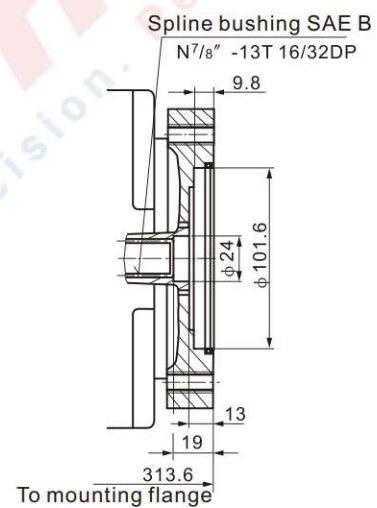
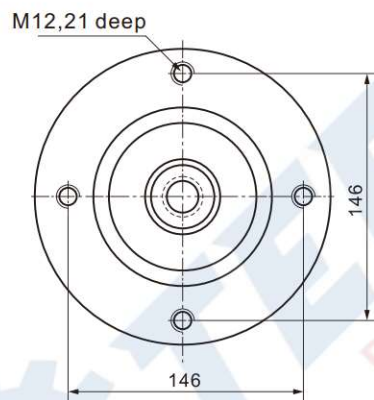

FOR MORE INFORMATION PLEASE CONTACT US

SALES@TECHYDRO.COM.CN



TECHYDRO

- ☎ +86-15869517019
- ✉ SALES@techhydro.com.cn
- 🌐 WWW.TECHYDRO.COM.CN
- 📞 whatsapp/Wechat: +86-15869517019
- ☎ TEL: +86(0574) -87021030